



Operating Instructions: CLA Lubrication System

**ORIGINAL OPERATING INSTRUCTIONS
READ CAREFULLY
RETAIN THIS DOCUMENT FOR LATER REFERENCE**

Operating Instructions: CLA Lubrication System

Imprint



Issue/Revision date: January 2021

Document revision: V01

Author: Anna Herzog

Copyright

This documentation is protected by copyright.

The rights in respect of layout and corporate design are owned by iwis antriebssysteme GmbH & Co. KG.

The rights in respect of contents and text are owned by iwis antriebssysteme GmbH & Co. KG.

iwis antriebssysteme GmbH & Co. KG reserves all rights, including the right to photomechanical communication, reproduction and distribution using special procedures (for example data processing, data media and data networks), even if only partial.

Subject to changes in content and technical modifications.

Sales: iwis antriebssysteme GmbH & Co. KG | Albert-Roßhaupter-Straße 53 | D-81369 Munich

Phone: +49 (0)89 76909-1600 | Fax: +49 (0)89 76909-1198

E-mail: sales@iwis.com | www.iwis.com

Operating Instructions: CLA Lubrication System

Table of contents

Content	Page
1. General information about this manual	6
1.1. Signal words	6
1.2. Warning symbols	6
1.3. Structure of the safety instructions	7
1.4. Symbols for information	7
2. Safety	8
2.1. EC/EU Directive	8
2.2. Hazards	8
2.3. Staff	8
2.4. Reasonably predictabel misuse	8
2.5. Usage for the intended purpose	8
2.6. Warranty and liability	9
2.7. General safety instructions	10
3. Description of function	11
3.1. General information	11
3.2. Nameplate and designation	12
3.3. Scope of delivery	12
3.4. Technical data	13
4. Transport and storage	14
4.1. Packaging	14
4.2. Transport	14
4.3. Storage	14
5. Variants	14
5.1. iwis CLA lubrication pump with one pump body and one outlet	15
5.2. iwis CLA lubrication pump with one pump body and two outlets	15
5.3. iwis CLA lubrication pump with two pump bodies and two outlets	16
5.4. iwis CLA lubrication pump with two pump bodies and three outlets	16
5.5. iwis CLA lubrication pump with two pump bodies and four outlets	17
6. Mounting	17
6.1. Preparations	17
6.2. Assembly	18
6.3. Commissioning the pulse-controlled version (PC)	21
6.4. Commissioning the time-controlled version (TC)	22

Content	Page
7. Operation and settings pulse-controlled version (PC)	23
7.1. General Information	23
7.2. Input and output signals – External control (PLC)	23
7.3. Pin assignment – External control (PLC).....	23
7.4. Input signals – External control (PLC)	24
7.4.1. Control signal 2 seconds	25
7.4.2. Control signal 5 seconds	26
7.4.3. Control signal 8 seconds	27
7.4.4. Control signal 12 Seconds	28
7.4.5. Control signal 14 seconds	29
7.5. Output signals – External control (PLC)	30
7.5.1. Empty level	31
7.5.2. Error overload.....	32
7.5.3. Error under- or overvoltage	32
7.5.4. Critical error	33
8. Operation and settings – time-controlled version (TC)	34
8.1. General information	34
8.2. Factory settings	34
8.2.1. Default settings Hour-Mode -h-.....	35
8.2.2. Default settings Empty-Time-Mode Et	35
8.3. Menu and LCD messages.....	36
8.3.1. LCD	38
8.3.2. Actions with the activation and programming key	40
8.3.3. Switching on and off	41
8.3.4. INF-Menu Hour-Mode -h-	42
8.3.5. INF-Menu operating mode Empty-Time-Mode Et	43
8.3.6. SET-Menu	44
8.3.7. RUN-Menu	46
8.3.8. PRO-Menu operating mode Hour-Mode -h-	47
8.3.9. PRO-Menu operating mode Empty-Time-Mode Et	50
8.3.10.FIL-Menu	53
8.4. Error codes	54
8.5. Input and output signals	55

Operating Instructions: CLA Lubrication System

Table of contents

Content	Page
8.5.1. Pin assignment – Time control	55
8.5.2. Output signals and LCD messages – time-controlled version	56
8.5.3. Output signals at PIN 4 – Time contro	56
9. Maintenance and disposal	58
9.1. Maintenance schedule	58
9.1.1. Visual check	58
9.1.2. Cleaning	58
9.1.3. Recommissioning after maintenance	58
9.2. Cartridge change	59
9.3. Disposal	60
10. Released accessories	60
10.1. Lubricants	60
10.2. Tube length	60
11. Appendix	61
11.1. Dimension sheet and installation dimensions	61
11.2. Flowchart Control signal 2 seconds (for PLC)	62
11.3. Commissioning the PU applicators	63

Operating Instructions: CLA Lubrication System

1. General information about this manual

This user manual contains all necessary information to use the iwis CLA lubrication pump safely and as intended. In the event that supplementary sheets are attached to these instructions, the information and data contained in the supplementary sheets are valid and replace the corresponding information in this user manual. Any contradictory information contained in this user manual thus becomes invalid. If you have any questions regarding special applications, please contact iwis antriebssysteme GmbH & Co. KG.

The actual and factual operator must ensure and guarantee that these instructions, including any supplementary sheets, have been read and understood by all persons responsible for the installation, operation or maintenance of the iwis CLA lubrication pump. Therefore, keep these instructions in a suitable place, ideally in an easily accessible place, in the surrounding area of the iwis CLA lubrication pump.

Inform your colleagues who work in the local area of the machine about safety instructions so that nobody gets hurt. The original manual was written in German, all other language versions are translations of this manual.

1.1. Signal words

The following signal words are used in this manual to draw your attention to possible dangers, prohibitions and other important information:

DANGER

This signal word points you to an immediate and threatening risk of serious injury or death.

WARNING

This signal word indicates a potentially imminent danger which can result in serious injury or even death.

CAUTION

This signal word indicates a potentially imminent danger that can result in minor to severe injuries.

NOTICE

This signal word indicates a potentially imminent danger which can result in damage to property.

INFO

This signal word refers to practical application tips or particularly important information when using the iwis CLA lubrication pump.

1.2. Warning symbols

The following warning symbols are used in this user manual to alert you to hazards, prohibitions and important information:



General
warning sign



Electricity
hazard



Flammable
material

Operating Instructions: CLA Lubrication System

1.3. Structure of the safety instructions

The safety instructions in this user manual are structured according to the following system:

	CAUTION
	<p>The text explains the consequences of disregarding the reference.</p> <ul style="list-style-type: none">• The text shows what to do as an instruction

1.4. Symbols for information

The following information symbols are used in the text and instructions in this manual:

-  Additional information about the action

Operating Instructions: CLA Lubrication System

2. Safety

All persons working with the iwis CLA lubrication pump must follow these operating instructions, in particular the safety instructions and the rules and regulations applicable at the place of use. Generally applicable legal regulations and other rules as well as the relevant rules and regulations for accident prevention (e.g. Personal Protective Equipment (PPE)) and environmental protection must be observed.

2.1. EC/EU Directive

Within the scope of the EC/EU Directive, (re)commissioning of a machine on which the iwis CLA lubrication pump has been installed and/or fitted is prohibited until it has been clearly established that the machine complies with the provisions of the applicable Directive.

2.2. Hazards

In order to avoid danger to the user or damage to the machine on which the iwis CLA lubrication pump is used, the iwis CLA lubrication pump may only be used for its intended purpose (chapter 2.5) and in a technically safe condition. Always inform yourself about the general safety instructions (chapter 2.7) before starting to work.

2.3. Staff

Only qualified staff who has read and understood this manual may work with the iwis CLA lubrication pump. Local and/or company regulations apply accordingly.

2.4. Reasonably predictabel misuse

Any use of the iwis CLA lubrication pump which exceeds the maximum permissible technical data is generally considered to be improper and therefore prohibited.

2.5. Usage for the intended purpose

The following points must be observed for the intended purpose of using the iwis CLA lubrication pump:

- The iwis CLA lubrication pump is exclusively approved for industrial use.
- The iwis CLA lubrication pump may be used exclusively in accordance with the technical data (chapter 3.4).
- Unauthorized structural alterations to the iwis CLA lubrication pump are not permitted.
- Read the user manual and act accordingly.
- During operation of the iwis CLA lubrication pump, a visual inspection of the iwis CLA lubrication pump as well as of the lubrication point must be carried out regularly. Any anomalies must be eliminated immediately and the cause rectified.
- Refilling the cartridge is not permitted.
- Only lubricants approved by the manufacturer may be used.
- Relevant regulations and rules on work safety, accident prevention and environmental protection must be observed.
- Work and activities with and on the iwis CLA lubrication pump are only permitted with appropriate authorisation (Chapter 2.3).

All other uses than the aforementioned intended usage or the disregard of one of the above points shall be deemed improper usage. In this case no liability and/or warranty is assumed.

Operating Instructions: CLA Lubrication System

2.6. Warranty and liability





If the following items are disregarded, all warranty and liability claims for personal injury and/or damage to property are excluded:

- Non-observance of the instructions for transport and storage
- Misuse
- Improper or unperformed maintenance or repair work
- Improper assembly/disassembly or improper operation
- Operation of the iwis CLA lubrication pump with defective protective devices
- Operation of the iwis CLA lubrication pump without lubricant
- Operation of the iwis CLA lubrication pump with non-approved lubricant
- Operation of a heavily contaminated iwis CLA lubrication pump
- Modifications or alterations which have been carried out without the written permission of iwis antriebssysteme GmbH & Co. KG
- Opening and/or partial or complete disassembly of the iwis CLA lubrication pump

Operating Instructions: CLA Lubrication System

2.7. General safety instructions

The following safety instructions are given for the iwis CLA lubrication pump:

	<p style="text-align: center;">DANGER</p> <p>Damaged or incorrect electrical connections or unauthorized live components lead to serious injuries or even death.</p> <ul style="list-style-type: none"> • Have all electrical connection work carried out by qualified personnel only. • Replace damaged cables or plugs immediately.
	<p style="text-align: center;">NOTICE</p> <p>Loose or overloaded screw connections can cause damage to the iwis CLA lubrication pump.</p> <ul style="list-style-type: none"> • Mount and check all screw connections with the permissible torques specified for this purpose. Use a calibrated torque wrench.
	<p style="text-align: center;">WARNING</p> <p>Lubricants are flammable.</p> <ul style="list-style-type: none"> • In case of fire, do not use a water jet to extinguish the fire. • In case of fire, use only suitable extinguishing agents such as powder, foam and carbon dioxide. • Observe the relevant safety instructions of the lubricant manufacturer on the safety data sheet of the lubricant used.
	<p style="text-align: center;">CAUTION</p> <p>Lubricants can cause skin irritations.</p> <ul style="list-style-type: none"> • Avoid direct skin contact.
	<p style="text-align: center;">NOTICE</p> <p>Lubricants can contaminate soil and water.</p> <ul style="list-style-type: none"> • Use and dispose lubricants properly.

Operating Instructions: CLA Lubrication System

3. Description of function

The following safety instructions are given for the iwis CLA lubrication pump:

3.1. General information

The iwis CLA lubrication pump is designed as an extremely compact double piston pump for autonomous operation with grease as the lubricant. The two pistons run force-controlled and counter-rotating. The iwis CLA lubrication pump is available as a version with one lubricant outlet or as a version with two lubricant outlets. The outlets are secured by an integrated non-return valve. Approx. 0.15 cm³ of lubricant is pumped during each dispensing operation; multiple dispensers can be set one after the other.

The present iwis CLA pump version has to be integrated into an external control (e.g. PLC). The iwis CLA pump has an electrical interface with which you can control and command the iwis CLA pump. Furthermore, the iwis CLA pump enables remote monitoring by output signals in order to be able to query the status and possible error messages (e.g. empty cartridge). By means of various input signals processed by the microelectronics, the iwis CLA pump is controlled to supply the lubrication point with the ideal amount of lubricant.

- i** The iwis CLA lubrication pump is equipped with a special oil cartridge, which must not be exchanged. Further is a float integrated in the oil cartridge, which transmits a signal to the microelectronics when the cartridge is empty.



Abb.1.1: Overview iwis CLA lubrication pump – pulse-controlled version

- | | |
|--|--|
| 0 Pulse-controlled iwis CLA lubrication pump (no LCD display) | 5 Nameplate with designation, CE mark and serial number |
| 1 Lubricant outlet, outlets (different versions possible) | 6 Through hole for assembly |
| 2 Retaining ring | 7 Lubricant inlet with thread for cartridge |
| 3 Housing | 8 Float |
| 4 M12x1 electrical interface | 9 Oil cartridge |

Operating Instructions: CLA Lubrication System

The LCD on the front panel displays the various operating states; further information (empty cartridge, error) can be read. The present iwis CLA pump as power supply version has an electrical interface. The supplied activation and programming key can be used to adjust the operation mode and the quantity of lubricant pumped per time in order to supply the lubrication point with the ideal quantity of lubricant.

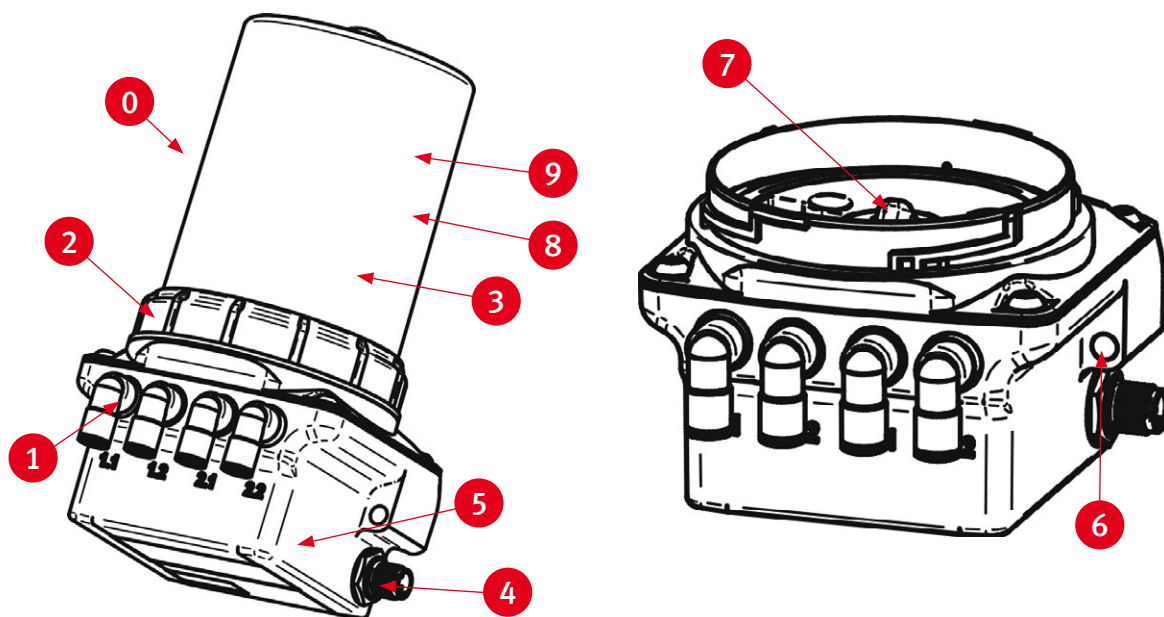

Abb. 1.2: Overview iwis CLA lubrication pump – time-controlled version

- | | |
|---|---|
| 0 Time-controlled iwis CLA lubrication pump | 6 Housing |
| 1 LCD | 7 M12x1-electrical interface |
| 2 Action area (for actions with the activation and programming key) | 8 Nameplate with designation, CE mark and serial number |
| 3 Activation and programming key | 9 Through hole for assembly |
| 4 Lubricant outlet, outlets (different versions possible) | 10 Lubricant inlet with thread for cartridge |
| 5 Retaining ring | |

3.2. Nameplate and designation

The nameplate of the iwis CLA lubrication pump is visibly attached to the side of the pump itself. There the CE mark and the serial number of the iwis CLA lubrication pump are visible. Refer to chapter 3, Fig. 1 for the location of the nameplate and serial number.

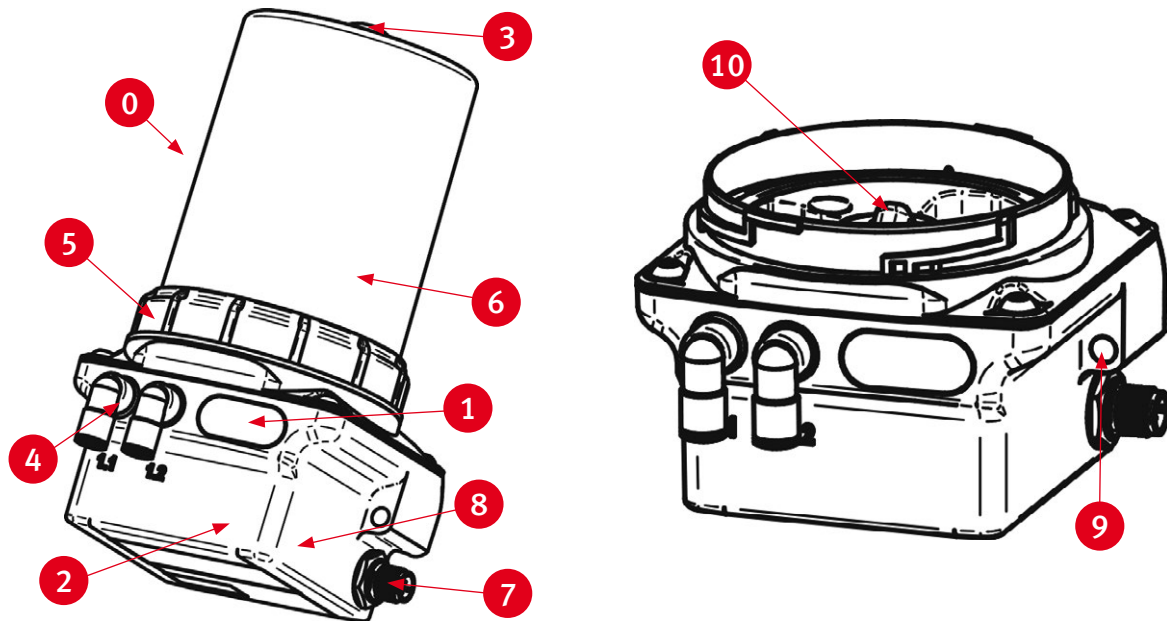
3.3. Scope of delivery

The iwis CLA lubrication pump is available in several different versions. They differ in the design (housing for 250ml cartridge or housing for 400ml cartridge), the number and type of lubricant outlets and the scope of accessories supplied.

Operating Instructions: CLA Lubrication System

3.4. Technical data

Housing

Dimensions without cartridge	111 x 56,5 x 108 (H x W x D)	mm
Dimensions with housing for 400ml cartridge	111 x 198,5 x 108 (H x W x D)	mm
Weight (without cartridge)	Approx. 1450	g
Mounting options	holes for screw M6	
Mounting position	vertical	
Material	Zinc die-cast / PA 6.6 GF30 / POM	
Material outlet	Nickel-plated brass	
Operating temperature	-15 ... +60*	°C

Lubricant and hydraulics

Cartridge volume	400	ml
Lubricant characteristics	Oil	
Number of outlets CLA pump Pulse-controlled	1 / 2 / 3 / 4	
Number of outlets CLA pump Time-controlled	1 / 2	
Hydraulic connection	via PA-Tube	
Number of lubrication points per outlet	up to 4 in connection with splitter* up to 10 in conjunction with aluminum progressive distributor*	
max. pressure	70 (-10%/+15%)	bar
Steady state pressure	70	bar
Grease delivery	per stroke 0,15	cm ³

Electrics

Display CLA Pumpe pulse-controlled	Not available	
Display CLA Pumpe time-controlled	LCD	
Operating voltage	24 (20V...28V) bzw. +/-5%	V
Protection	0,75 (slow blow)	A
Protection class	IP 54	
Current consumption	$I_{\max} < 0,3$ $I_{\text{quiescent}} < 0,025$	A

Further information on electrics can be found in chapter 7 and 8!

* The stated value depends on the specific application and may vary considerably in individual cases depending on the lubricant used and other conditions.

Operating Instructions: CLA Lubrication System

4. Transport and storage

4.1. Packaging

The iwis CLA lubrication pump is delivered in an outer packaging (cardboard box) and - depending on the scope of delivery with a lubricant cartridge and other accessories - in the same package.

To protect them from moisture and dirt, they are also packed in PE films. Dispose the packaging materials at the designated disposal points in compliance with the relevant national and company regulations.

After receiving the iwis CLA lubrication pump, check the delivery note for completeness and correctness. Any missing parts or damage must be reported immediately to the forwarding agent, the insurance company or iwis antirebssysteme GmbH & Co. KG in writing.

4.2. Transport

	NOTICE
	<p>Hard shocks, e.g. due to falling or setting down too hard, can damage the iwis CLA lubrication pump.</p> <ul style="list-style-type: none"> • Do not throw iwis CLA lubrication pump.

4.3. Storage

Store the iwis CLA lubrication pump in its original packaging in a vertical position in a dry, frost-free environment at an ambient temperature of +5°C to +30°C. The maximum storage time in unopened condition is 2 years.

The so-called „First-In-First-Out-Principle“ (FiFo) is recommended for storage logistics.

5. Variants

The iwis CLA lubrication pump is designed as a compact central lubrication unit for supplying one or more lubrication points. Depending on the specific application, the iwis CLA lubrication pump can also reliably and cleanly supply a limited number of lubrication points with lubricant. In this case, parts of the system accessories from the manufacturer (e.g. splitters, progressive distributors or lubrication gears) can be connected to the iwis CLA lubrication pump in order to extend the number of lubrication points beyond the number of outlets. The iwis CLA lubrication pump is available as a variant with one or as a variant with two pump bodies. The outlets of pump body (PB) 1 are marked on the housing with 1.1 and 1.2, the outlets of pump body 2 with 2.1 and 2.2.

Operating Instructions: CLA Lubrication System

5.1. iwis CLA lubrication pump with one pump body and one outlet

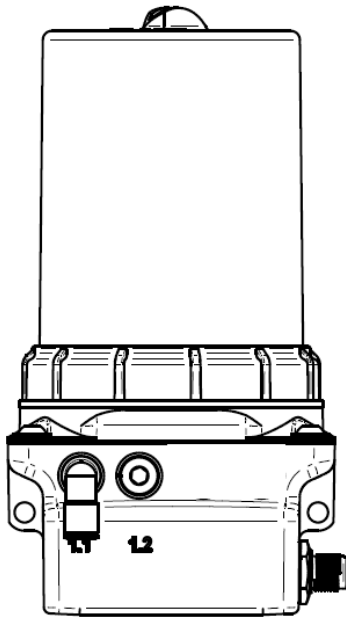

Number of pump units	1
Number of outlets	1
Differences in dosing volume per pump unit possible	Not applicable, as only one pump unit
Types of pump	Pulse-controlled or time controlled

With the iwis CLA lubrication pump, the theoretical two outlets of the built-in one pump unit are combined internally. The outlet is supplied with 0.15cm^3 lubricant per stroke.

5.2. iwis CLA lubrication pump with one pump body and two outlets

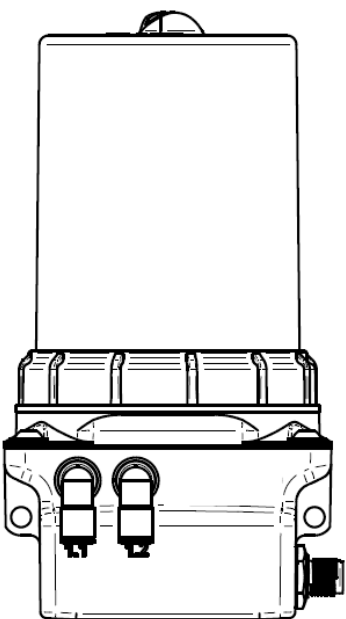

Number of pump units	1
Number of outlets	2
Differences in dosing volume per pump unit possible	Not applicable, as only one pump unit
Types of pump	Pulse-controlled or time controlled

With the iwis CLA lubrication pump, two outlets are supplied with the same quantity of lubricant. One outlet is supplied with 0.15cm^3 lubricant per stroke. The outlets are supplied with lubricant one after the other.

Operating Instructions: CLA Lubrication System

5.3. iwis CLA lubrication pump with two pump bodies and two outlets

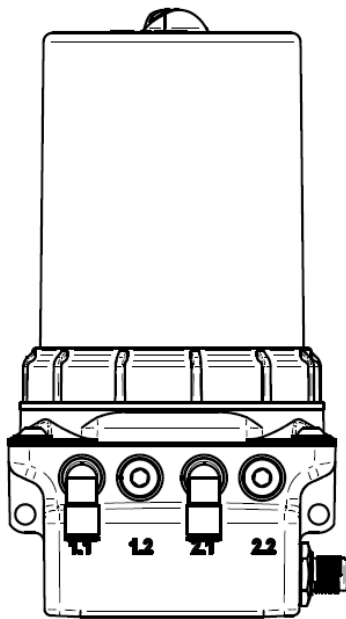

Number of pump units	2
Number of outlets	2
Differences in dosing volume per pump unit possible	Yes
Types of pump	Only pulse-controlled version

With the iwis CLA lubrication pump, the theoretical two outlets per installed pump unit are combined internally. One outlet is supplied with 0.15cm³ lubricant per stroke. The outlets are supplied with lubricant one after the other.

The iwis CLA lubrication pump allows to set dosing volume differences from outlet 1.1 to outlet 2.1 by individual control of the two pump bodies. An explanation of the different control signals can be found in chapter 7.4.

5.4. iwis CLA lubrication pump with two pump bodies and three outlets

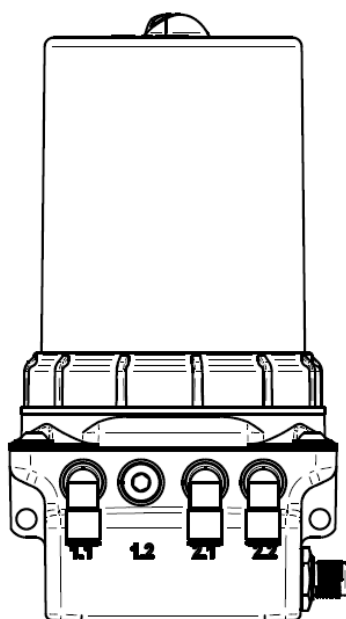

Number of pump units	2
Number of outlets	3
Differences in dosing volume per pump unit possible	Yes
Types of pump	Only pulse-controlled version

In the iwis CLA lubrication pump, the theoretical two outlets of the first pump body are internally combined into one outlet 1.1. One outlet is supplied with 0.15 cm³ lubricant per stroke. The outlets are supplied with lubricant one after the other.

The iwis CLA lubrication pump allows you to set dosing volume differences from outlet 1.1 to outlets 2.1 and 2.2 by controlling the two pump bodies individually. An explanation of the different control signals can be found in chapter 7.4.

i If the two pump units are controlled equally, outlet 1.1 is supplied with twice the amount of lubricant of outlets 2.1 or 2.2, due to the internal combination of the outlets of the first pump unit.

Operating Instructions: CLA Lubrication System

5.5. iwis CLA lubrication pump with two pump bodies and four outlets

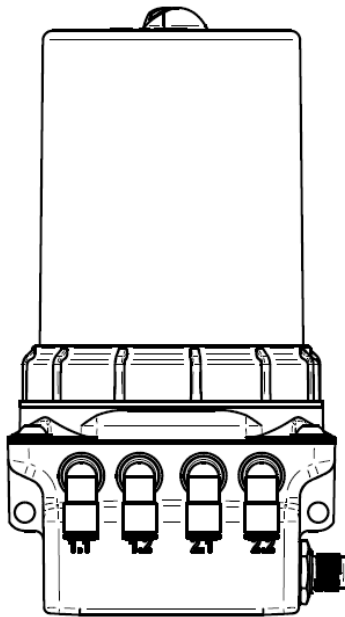

Number of pump units	2
Number of outlets	4
Differences in dosing volume per pump unit possible	Yes
Types of pump	Only pulse-controlled version

With the iwis CLA lubrication pump, each possible outlet is operated individually. One outlet is supplied with 0.15 cm³ lubricant per stroke. The outlets are supplied with lubricant one after the other.

The iwis CLA lubrication pump allows you to set dosing volume differences from outlets 1.1 and 1.2 to outlets 2.1 and 2.2 by individually controlling the two pump bodies. An explanation of the different control signals can be found in chapter 7.4.

6. Mounting

6.1. Preparations

Before starting to work, inform yourself in detail about the iwis CLA lubrication pump using this user manual; in particular about the general safety instructions (section 2.7). Prepare the installation site carefully.



NOTICE

Pressurised air can damage the seals of the iwis CLA lubrication pump and can transport dirt and foreign matter into the pump or the lubricant.

- Do not use pressurised air.
- Make sure that there is no coarse dirt in the mounting area.

Operating Instructions: CLA Lubrication System

6.2. Assembly

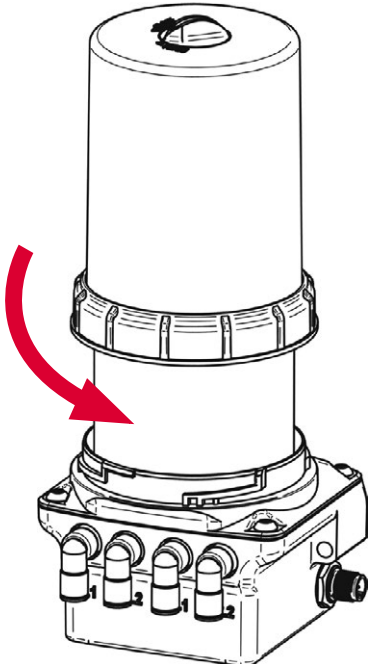
<p>Step 1</p>	<p>Condition as delivered</p> <p>The iwis CLA lubrication pump is delivered in a cardboard box. Depending on the version ordered, further accessories such as a lubricant cartridge or additional tube connection parts are included.</p>
<p>Step 2</p> 	<p>Remove the housing from the power unit of the iwis CLA lubrication pump.</p> <p>Separate the housing from the power unit by turning the retaining ring counterclockwise.</p> <ul style="list-style-type: none"> i Make sure that no dirt, water or foreign bodies enters the lubricant inlet. i As alternative you can remove the lid on top of the housing, to lay open the oil reservoir. Turn the lid to OPEN and pull it off.
<p>Step 3</p>	<p>Filling of the cartridge with oil.</p> <p>Fill the cartridge with oil until the mark “max. Füllstand” is reached.</p> <ul style="list-style-type: none"> i Pay attention to cleanliness when carrying out the work. It is imperative that dirt and foreign bodies do not enter the cartridge.

Operating Instructions: CLA Lubrication System

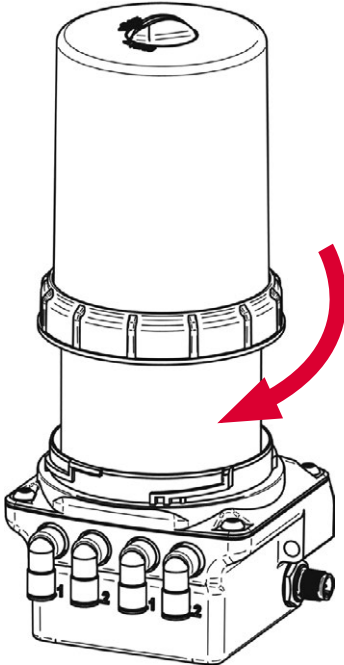
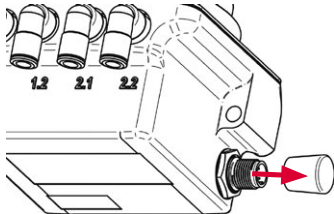
<p>Step 4</p> 	<p>Assembly the housing on the power unit of the iwis CLA lubrication pump.</p> <ul style="list-style-type: none"> Place the dismantled housing on the iwis CLA lubrication pump and press it onto the power unit. Fasten the housing to the power unit by turning the retaining ring clockwise. <p>i The retaining ring must snap into place when turning and be completely tightened.</p> <p>i Mount the lid back onto the housing, if you removed it for filling the oil cartridge. The lid has to be in the position CLOSE.</p>
<p>Step 5</p> 	<p>Remove the protective cap on the side of the iwis CLA lubrication pump.</p> <ul style="list-style-type: none"> Remove the black protective cap from the side of the electrical M12x1 interface.
<p>Step 6.1</p>	<p>Connecting the electrical interface (Pulse-controlled variant)</p> <ul style="list-style-type: none"> Connect the iwis CLA lubrication pump to the external power supply or controller via the M12x1 interface on the side of the iwis CLA lubrication pump using a suitable connecting cable. <p>i Depending on the application, both connection cables with straight or angled sockets can be used.</p> <p>i Please refer to chapter 7.3 for the condition of the connection cable.</p>

Operating Instructions: CLA Lubrication System

<p>Step 6.2</p>	<p>Connecting the electrical interface (time-controlled pump)</p> <ul style="list-style-type: none"> • Connect the iwis CLA lubrication pump to the external power supply or controller via the M12x1 interface on the side of the iwis CLA lubrication pump using a suitable connecting cable. i Depending on the application, both connection cables with straight or angled sockets can be used. i Please refer to chapter 8.5.1 for the condition of the connection cable.
-----------------	--

	DANGER
	<p>Defective or faulty electrical connections or unauthorized live components can lead to serious injuries or even death.</p> <ul style="list-style-type: none"> • Have all electrical connection work carried out by qualified personnel only. • Replace damaged cables or plugs immediately. • Before carrying out any electrical installation work, observe the five safety rules of electrical engineering: <ul style="list-style-type: none"> – Unlocking – Secure against unintentional restarting. – Check that there is no voltage. – Ground and short-circuit. – Cover adjacent live parts.

Operating Instructions: CLA Lubrication System

6.3. Commissioning the pulse-controlled version (PC)

Mount the iwis CLA lubrication pump carefully according to the steps described in chapter 6.2. Depending on the scope of delivery, you must also carry out the following additional measures for the first-time commissioning:

1. Mechanical fastening

Fix the iwis CLA lubrication pump mechanically. Pay particular attention to the maximum tightening torques permissible for the M5 female threads!

2. Electrical connection

Connect the iwis CLA lubrication pump to the external controller (PLC) via the M12x1 interface using a suitable cable. The iwis CLA lubrication pump is thus switched on.

3. Check the assembly

Make sure that the iwis CLA lubrication pump is properly and completely assembled. In particular, the battery must be inserted and a lubricant cartridge must be fitted.

4. Execute 12 seconds control signal

Execute the 12 seconds control signal. The detailed description can be found in chapter 7.4.4. iwis CLA lubrication pump performs a certain number of strokes and transports the lubricant from the cartridge to the outlet.

5. Hydraulic connection

Connect the consumer hydraulically to the iwis CLA lubrication pump. If you connect tubes to the iwis CLA lubrication pump, make sure that the tubes and connectors are installed tightly, cleanly and correctly.

i Ideally, use tubes prefilled with the appropriate lubricant!

6. Check the settings on the iwis CLA lubrication pump

Check the basic settings of the iwis CLA lubrication pump with the required values required for the lubrication point and adjust them if necessary. Changes must be made in the PLC program.

Operating Instructions: CLA Lubrication System

6.4. Commissioning the time-controlled version (TC)

Mount the iwis CLA lubrication pump carefully according to the steps described in chapter 6.2. Depending on the scope of delivery, you must also carry out the following additional measures for the first-time commissioning:

1. Mechanical fastening

Fix the iwis CLA lubrication pump mechanically. Pay particular attention to the maximum tightening torques permissible for the M5 female threads!

2. Electrical connection

Connect the iwis CLA lubrication pump to the external power supply or external controller (PLC) via the M12x1 interface using a suitable cable.

3. Check the assembly

Make sure that the iwis CLA lubrication pump is properly and completely assembled. In particular, the battery must be inserted and a lubricant cartridge must be fitted.

4. Power on

If you want to put the iwis CLA lubrication pump into operation, switch on the iwis CLA lubrication pump. Only if you switch the iwis CLA lubrication pump on, it delivers lubricant to the lubrication point according to the settings.

5. Execute FIL function

Execute the FIL function. The detailed description can be found in chapter 8.3.10. iwis CLA lubrication pump performs a certain number of strokes and transports the lubricant from the cartridge to the outlet.

6. Hydraulic connection

Connect the consumer hydraulically to the iwis CLA lubrication pump. If you connect tubes to the iwis CLA lubrication pump, make sure that the tubes and connectors are installed tightly, cleanly and correctly.

 Ideally, use tubes prefilled with the appropriate lubricant!

7. Check the settings iwis CLA-Pumpe

Check the factory settings of iwis CLA lubrication pump with the required values for the lubrication point and adjust them if necessary. Changes at the iwis CLA lubrication pump must be made in the SET-Menu.

Operating Instructions: CLA Lubrication System

7. Operation and settings pulse-controlled version (PC)

7.1. General Information

- i** To use the iwis CLA lubrication pump, it first has to be properly mounted and installed. The installation is very simple and described in detail in chapter 6.2.

What you should know about operating and setting the iwis CLA lubrication pump:

- If you have any questions about your application and the correct settings for the iwis CLA lubrication pump, please contact the manufacturer.
- For operation, the iwis CLA lubrication pump must be integrated into a control system (PLC) and must be commanded and controlled via the PLC. The iwis CLA lubrication pump delivers one or more strokes (one stroke = 0.15 cm³) depending on the signals of the external control (PLC). Depending on the internal status of the iwis CLA lubrication pump (e.g. cartridge empty), different output signals are issued by the iwis CLA lubrication pump.
- Make sure that your PLC program is correct for your application and that the lubrication point is supplied with the correct amount of lubricant per time unit. If this is the case, you can operate the iwis CLA lubrication pump.
- If this is not the case, change your PLC program accordingly.

7.2. Input and output signals – External control (PLC)

The iwis CLA lubrication pump operates as a pulse-controlled lubrication system only if unalterable input signals (high level) are transmitted from the PLC to the iwis CLA lubrication pump via PIN 2 in a defined sequence. The iwis CLA lubrication pump signals the respective status to the PLC via high/low levels, which can be tapped off at PIN 4, and thus enables comprehensive control or, by suitable programming of the PLC, differentiated evaluation of the different statuses. For the integration of the iwis CLA lubrication pump into an external control, one input and one output must be provided on the control side.

7.3. Pin assignment – External control (PLC)

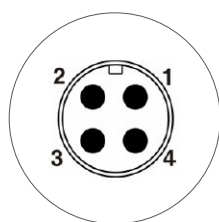

PIN	Assignment	Colour
1	+24 V DC	brown
2	Input Signal PLC → iwis CLA lubrication pump	white
3	Ground (GND)	blue
4	Output Signal iwis CLA lubrication pump → PLC	black

Type: M12x1 female connector; 4-pin, A-coded

For the electrical connection to an external control (PLC) of a system, the iwis CLA lubrication pump has a 4-pin interface, which is designed as a plug connection with the standard industrial M12x1 connection.

Operating Instructions: CLA Lubrication System

- i** The iwis CLA lubrication pump can be switched off completely by switching off the supply voltage. After reapplying the supply voltage, the iwis CLA lubrication pump checks itself automatically but only operates after receiving an input signal from the PLC.
- i** To operate the iwis CLA lubrication pump via an external controller (PLC), a program corresponding to the communication protocol must be created in the PLC. A basic flowchart for the command of the iwis CLA lubrication pump can be found in the appendix (chapter 11.2).
- i** The output signal at PIN 4 can be tapped for further processing (e.g. indicator light or external control). The maximum permissible output current must not exceed $I_{max} < 20\text{mA}$. No inductive load (e.g. relay) may be connected!
- i** After a longer standstill of the iwis CLA lubrication pump the manual execution of the „Quick-Check“ is recommended. You can use for example the 12 seconds control signal to trigger a certain number of donations via the PLC (chapter 7.4).

7.4. Input signals – External control (PLC)

The iwis CLA lubrication pump provides the following unalterably defined control signals (input signals), which must be transmitted from the PLC to the iwis CLA lubrication pump via PIN 2 of the electrical M12x1 interface as high level (+24 V DC).

The control signals must be generated as high level (+24 V) by the external controller (PLC) over certain times with a tolerance of +/- 0.1 seconds.

Signal length in seconds	Description	Function	Detail / Chapter
2 high	Signal 2 Seconds	1 Stroke PK1	7.4.1
5 high	Signal 5 Seconds	1 Stroke PK2	7.4.2
8 high	Signal 8 Seconds	1 Stroke PK1 and PK2	7.4.3
12 high	Signal 12 Seconds	FIL-Function	7.4.4
14 high	Signal 14 Seconds	Error acknowledgement	7.4.5

- i** The input signals that your iwis CLA lubrication pump can process depend on the design of the iwis CLA lubrication pump. Compare your iwis CLA lubrication pump with the different designs described in chapter 5 to find out which signals are important for your iwis CLA lubrication pump and can be used for control. The designation of your iwis CLA lubrication pump can be found on the nameplate attached to the side of the iwis CLA lubrication pump, see chapter 3.1, fig. 1.
- i** The iwis CLA lubrication pump only processes the control signals listed in the table up to a maximum length of 14 seconds. If a high level (+24 V DC) is present outside the tolerances, the iwis CLA lubrication pump does not react. If a high level (+24 V DC) is applied to PIN 2 of the electrical interface for longer than 15 seconds, the LCD will display --- and the iwis CLA lubrication pump will not react.

Operating Instructions: CLA Lubrication System

7.4.1. Control signal 2 seconds

The control signal 2 seconds triggers a single dispensing process. After a specified pause time, this control signal can be repeated or another control signal can be sent.

The iwis CLA lubrication pump reacts only in a certain operating state to control signals at PIN 2. The operating states are output by the iwis CLA lubrication pump via PIN 4 as a high/low level and must be tapped and processed accordingly in the PLC.

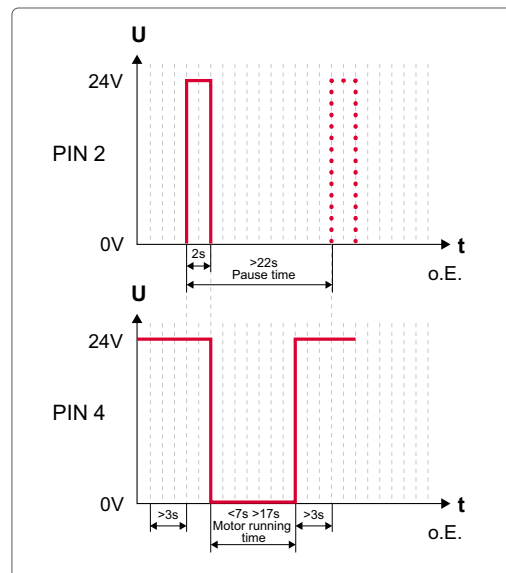

Description:

The iwis CLA lubrication pump is properly connected to an external controller via the electrical interface and connected to the power supply.

- The iwis CLA lubrication pump sends a permanent output signal (high level) to PIN 4, which indicates to the external control (PLC) that it is ready for operation. This output signal must be permanently and continuously present for >3 seconds. Control by the external controller is only possible if this condition is present.
 - The control signal 2 seconds with a signal length of 2 (1.9 ... 2.1) seconds high level can be sent from the external control (PLC) to the iwis CLA lubrication pump .
 - Immediately after the control signal drops, the motor run (ML) of the iwis CLA lubrication pump starts and 0.15 cm³ lubricant is conveyed to the outlet. Simultaneously with the start of the motor run (ML), the iwis CLA lubrication pump sends a low level output signal to the external controller (PLC) as confirmation for the duration of the motor run (ML).
 - The motor running time (ML) depends on various conditions, including the counterpressure present or built up in the hydraulic system and the temperature. With the iwis CLA lubrication pump, the motor running time (ML) is 7...17 seconds.
 - At the end of an error-free and successful motor run (ML), the output signal at iwis CLA lubrication pump changes from a low level to a high level.
- i** A possible next control signal can be sent from the external controller (PLC) at the earliest >3 seconds after the end of the error-free and successful motor run. In the meantime, the iwis CLA lubrication pump does not process any control signals.
- i** In order to ensure a reliable and unambiguous recognition of the control signal, a pause must be observed. For the control signal 2 seconds, the iwis CLA lubrication pump requires a pause time (Tp) of at least 22 seconds between two identical or different control signals.
- i** If the integrated microelectronics of the iwis CLA lubrication pump has detected an error during or immediately after the end of the motor run (ML), this is transmitted to the external controller (PLC) by the corresponding output signal (section 7.5).

Operating Instructions: CLA Lubrication System

7.4.2. Control signal 5 seconds

The 5 second control signal triggers a single dispensing operation on pump unit 2 when a pump unit 2 is present. After a certain pause time, this control signal can be repeated or another control signal can be sent.

The iwis CLA lubrication pump reacts only in a certain operating state to control signals at PIN 2. The operating states are output by the iwis CLA lubrication pump via PIN 4 as a high/low level and must be tapped and processed accordingly in the PLC.

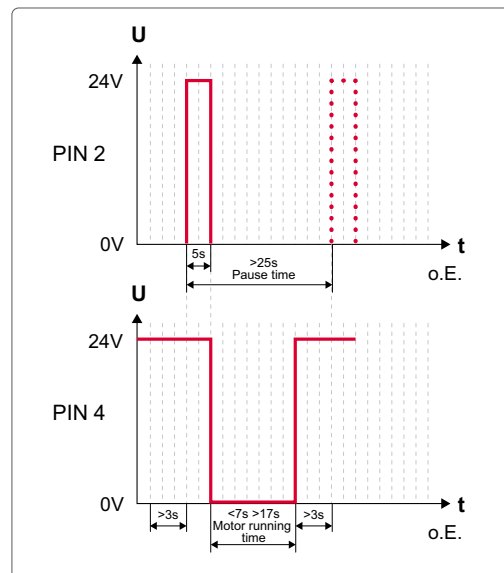

Description:

The iwis CLA lubrication pump is properly connected to an external controller via the electrical interface and connected to the power supply.

- The iwis CLA lubrication pump sends a permanent output signal (high level) to PIN 4, which indicates to the external control (PLC) that it is ready for operation. This output signal must be permanently and continuously present for >3 seconds. Control by the external controller is only possible if this condition is present.
 - The control signal 5 seconds with a signal length of 5 (4.9 ... 5.1) seconds high level can be sent from the external control (PLC) to the iwis CLA lubrication pump.
 - Immediately after the control signal drops, the motor run (ML) of the iwis CLA lubrication pump starts and 0.15 cm^3 lubricant is conveyed to the outlet. Simultaneously with the start of the motor run (ML), the iwis CLA lubrication pump sends a low level output signal to the external controller (PLC) as confirmation for the duration of the motor run (ML).
 - The motor running time (ML) depends on various conditions, including the counterpressure present or built up in the hydraulic system and the temperature. With the iwis CLA lubrication pump, the motor running time (ML) is 7...17 seconds.
 - At the end of an error-free and successful motor run (ML), the output signal at iwis CLA lubrication pump changes from a low level to a high level.
- i** A possible next control signal can be sent from the external controller (PLC) at the earliest >3 seconds after the end of the error-free and successful motor run. In the meantime, the iwis CLA lubrication pump does not process any control signals.
- i** In order to ensure a reliable and unambiguous recognition of the control signal, a pause must be observed. For the control signal 5 seconds, the iwis CLA lubrication pump requires a pause time (T_p) of at least 25 seconds between two identical or different control signals.
- i** If the integrated microelectronics of the iwis CLA lubrication pump has detected an error during or immediately after the end of the motor run (ML), this is transmitted to the external controller (PLC) by the corresponding output signal (section 7.5).

Operating Instructions: CLA Lubrication System

7.4.3. Control signal 8 seconds

The 8 second control signal triggers a single dispensing operation at pump unit 1 and pump unit 2 when pump unit 2 is present. After a certain pause time, this control signal can be repeated or another control signal can be sent.

The iwis CLA lubrication pump reacts only in a certain operating state to control signals at PIN 2. The operating states are output by the iwis CLA lubrication pump via PIN 4 as a high/low level and must be tapped and processed accordingly in the PLC.

Description:

The iwis CLA lubrication pump is properly connected to an external controller via the electrical interface and connected to the power supply.

- The iwis CLA lubrication pump sends a permanent output signal (high level) to PIN 4, which indicates to the external control (PLC) that it is ready for operation. This output signal must be permanently and continuously present for >3 seconds. Control by the external controller is only possible if this condition is present.
 - The control signal 8 seconds with a signal length of 8 (7.9 ... 8.1) seconds high level can be sent from the external control (PLC) to the iwis CLA lubrication pump.
 - Immediately after the control signal drops, the motor run (ML) of the iwis CLA lubrication pump starts and 0.15 cm³ lubricant is conveyed to the outlet. Simultaneously with the start of the motor run (ML), the iwis CLA lubrication pump sends a low level output signal to the external controller (PLC) as confirmation for the duration of the motor run (ML).
 - The motor running time (ML) depends on various conditions, including the counterpressure present or built up in the hydraulic system and the temperature. With the iwis CLA lubrication pump, the motor running time (ML) is 7...17 seconds.
 - At the end of an error-free and successful motor run (ML), the output signal at iwis CLA lubrication pump changes from a low level to a high level.
- i** Possible next control signal can be sent from the external controller (PLC) at the earliest >3 seconds after the end of the error-free and successful motor run. In the meantime, the iwis CLA lubrication pump does not process any control signals.
 - i** In order to ensure a reliable and unambiguous recognition of the control signal, a pause must be observed. For the control signal 5 seconds, the iwis CLA lubrication pump requires a pause time (Tp) of at least 45 seconds between two identical or different control signals.
 - i** If the integrated microelectronics of the iwis CLA lubrication pump has detected an error during or immediately after the end of the motor run (ML), this is transmitted to the external controller (PLC) by the corresponding output signal (section 7.5).

Operating Instructions: CLA Lubrication System

7.4.4. Control signal 12 Seconds

The control signal for 12 seconds triggers the FIL function by the external control. A total of 40 dispensing operations per pump unit are carried out automatically one after the other. After a certain pause time, this control signal can be repeated or another control signal can be sent.

The iwis CLA lubrication pump reacts only in a certain operating state to control signals at PIN 2. The operating states are output by the iwis CLA lubrication pump via PIN 4 as high/low levels and must be tapped and processed accordingly in the PLC.

Description:

The iwis CLA lubrication pump is properly connected to an external controller via the electrical interface and connected to the power supply.

- The iwis CLA lubrication pump sends a permanent output signal (high level) to PIN 4, which indicates to the external control (PLC) that it is ready for operation. This output signal must be permanently and continuously present for >3 seconds. Control by the external controller is only possible if this condition is present.
 - The control signal 2 seconds with a signal length of 12 (11.9 ... 12.1) seconds high level can be sent from the external control (PLC) to the iwis CLA lubrication pump .
 - Immediately after the control signal drops, the motor run (ML) of the iwis CLA lubrication pump starts and 0.15 cm³ lubricant is conveyed to the outlet. Simultaneously with the start of the motor run (ML), the iwis CLA lubrication pump sends a low level output signal to the external controller (PLC) as confirmation for the duration of the motor run (ML).
 - The motor running time (ML) depends on various conditions, including the counterpressure present or built up in the hydraulic system and the temperature. With the iwis CLA lubrication pump , the motor running time (ML) is 7...17 seconds.
 - At the end of each error-free and successful motor run (ML), the output signal at the iwis CLA lubrication pump changes from a low level to a high level for a short pause time P = 0.5 seconds.
 - EA total of 40 engine runs and donations will take place immediately one after the other. $40 \times 0.15 \text{ cm}^3 = 6.0 \text{ cm}^3$ lubricant is conveyed from the cartridge to the outlet.
- i** A possible next control signal can be sent from the external controller (PLC) at the earliest >3 seconds after the end of the error-free and successful motor run. In the meantime, the iwis CLA lubrication pump does not process any control signals.
 - i** In order to ensure a reliable and unambiguous recognition of the control signal, a pause must be observed. For the control signal 12 seconds, the iwis CLA lubrication pump has a pause time (Tp) between two identical or different control signals of at least 706 (Tp=MLmaxx40 strokes+Px40 strokes+tolerance) seconds.
 - i** For an iwis CLA lubrication pump with two pump units, 40 filling strokes per pump unit are triggered when the control signal is triggered for 12 seconds. The pause time (Tp) is doubled.
 - i** The integrated microelectronics of the iwis CLA lubrication pump has detected an error during or immediately after the end of the motor run (ML), it is transmitted to the external controller (PLC) by the corresponding output signal (section 7.5).

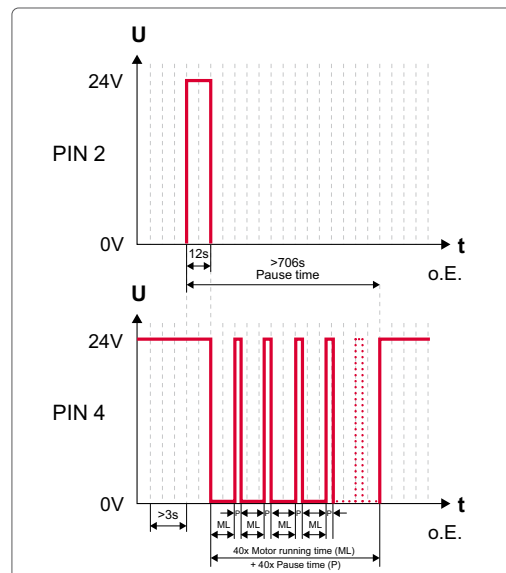

Operating Instructions: CLA Lubrication System

7.4.5. Control signal 14 seconds

The control signal 14 seconds is used to acknowledge error messages of errors E2 and E3. It is the only control signal that the iwis CLA lubrication pump can process when a low level output signal is sent. Irrespective of the basic possibility of remote acknowledgement of an error, it is essential to identify and eliminate the cause when an error message is present.

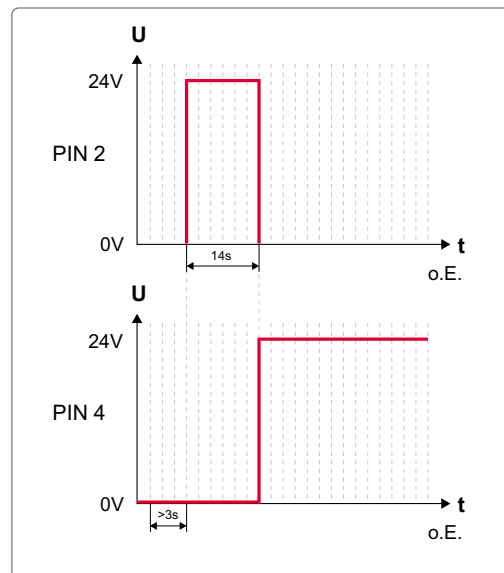

Description:

The iwis CLA lubrication pump is properly connected to an external controller via the electrical interface and connected to the power supply.

There is an error at the iwis CLA lubrication pump.

- The iwis CLA lubrication pump sends a permanent output signal (low level) to PIN 4, which indicates an error to the external controller (PLC). This output signal must be permanently and continuously present for >3 seconds.
 - The control signal 14 seconds with a signal length of 14 (13.9 ... 14.1) seconds high level can be sent from the external control (PLC) to the iwis CLA lubrication pump.
 - At the end of the control signal, the integrated microelectronics of the iwis CLA lubrication pump will automatically check itself:
 - If this internal check is successful, the output signal at the iwis CLA lubrication pump changes from a low level to a high level; the error is thus acknowledged and the iwis CLA lubrication pump is ready for operation again.
 - If this internal check is not successful, the iwis CLA lubrication pump continues to send a low level output signal. The error is still present. For further measures in this case: Chap. 7.5.4.
- i** A possible next control signal can be sent from the external controller (PLC) at the earliest >3 seconds after the end of the error-free and successful motor run. In the meantime, the iwis CLA lubrication pump does not process any control signals.
- i** Regardless of the principle of remote acknowledgement of an error, it is essential to identify and eliminate the cause when an error message is present.

Operating Instructions: CLA Lubrication System

7.5. Output signals – External control (PLC)

Description	Output signal (PIN 4)	Detail
Ready for operation	high, permanent	Chap. 7
Receiving control signal	high, permanent	Chap. 7
Dispensing process	low, 10...18 seconds	Chap. 7
Cartridge empty	0,5Hz-square wave signal, permanent	Chap. 7.5.1
Error	Low, permanent	Chap. 7.5.2-4

If an output signal as low level (0V) is permanently present at PIN 4 for longer than 3s and no dispensing process is currently being performed by the iwis CLA lubrication pump, there is an error at the iwis CLA lubrication pump. The only thing that can be determined by the signalling is that there is an error at the iwis CLA lubrication pump. The cause must be determined and eliminated by the operator. Chapters 7.3.2, 7.3.3 and 7.3.4 provide a procedure and possible causes for the pump error message.

Operating Instructions: CLA Lubrication System

7.5.1. Empty level

The iwis CLA lubrication pump is equipped with a sensor which detects the empty level of the lubricant cartridge. After reaching the empty level, the iwis CLA lubrication pump no longer delivers lubricant. This ensures that no air enters the iwis CLA lubrication pump or the lubricant lines. The empty state message (error E1) is transmitted to the external control (PLC).

For this purpose, a separate, unique output signal is provided, which can be easily and reliably detected by the external control (PLC).

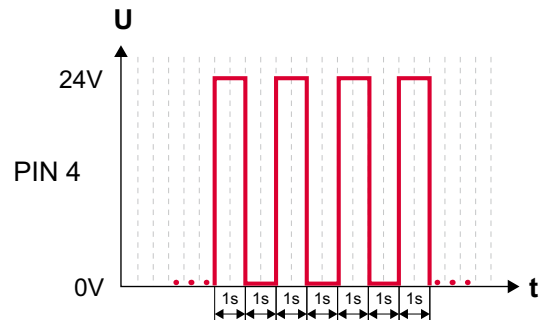

Description:

The iwis CLA lubrication pump is properly connected to an external controller via the electrical interface and connected to the power supply.

- The Empty state signal can only occur immediately after a donation.
- The Empty state signal must and cannot be acknowledged. Remedial action is described in chapter 9.2. At the same time as removing the cartridge, the iwis CLA lubrication pump sends a permanent low level (0V) as output signal to PIN 4.

i The iwis CLA lubrication pump does not process control signals until all errors have been eliminated.

The transition of the output signals when changing a cartridge on the iwis CLA lubrication pump is shown and described below:

Description:

The iwis CLA lubrication pump is properly connected to an external controller via the electrical interface and connected to the power supply.

- The empty state of the cartridge occurred after a donation, the output signal of the iwis CLA lubrication pump is initially the 0.5Hz square wave signal (empty state signal) (0/+24 V).
- Z1 indicates the time of removal of the empty cartridge. The output signal of the iwis CLA lubrication pump now changes from a 0.5Hz square wave signal to a permanent low signal (0V).
- Z2 indicates the time for refilling of the cartridge. The output signal of the iwis CLA lubrication pump now changes from a permanent low signal (0V) to a permanent high signal (+24V). In this way the iwis CLA lubrication pump signals to the external controller (PLC) that it is ready for operation again.
- If the empty state signal has occurred during the execution of the control signal 12 seconds, the outstanding strokes are continued after the cartridge has been refilled.

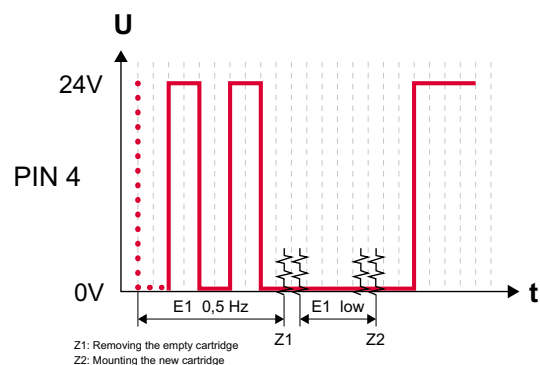

i The iwis CLA lubrication pump does not process control signals until all errors have been eliminated.

Operating Instructions: CLA Lubrication System

7.5.2. Error overload

The Error Overload signals a hydraulic overload during a dispensing process, i.e. the maximum pressure is exceeded.

Description:

The iwis CLA lubrication pump is properly connected to an external controller via the electrical interface and connected to the power supply.

The iwis CLA lubrication pump has been successfully controlled by the external control (PLC) immediately before the occurrence of error E2 and has (attempted) to perform a dispensing operation..

- When the maximum permissible pressure is reached during or after a donation, the iwis CLA lubrication pump sends a permanent output signal as low level (0 V) to PIN 4 for external control (PLC).
- Check the connecting lines from the iwis CLA lubrication pump to the lubrication points supplied and eliminate any possible causes.
- The error E2 (overload) must be acknowledged with the control signal 14 seconds (chapter 7.4.5.) after elimination of the cause(s).

i The iwis CLA lubrication pump does not process control signals until all errors have been eliminated.

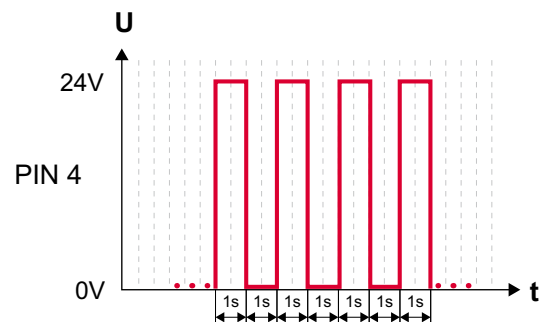

7.5.3. Error under- or overvoltage

Error Under- or Overvoltage indicates that the iwis CLA lubrication pump power supply is not within the specified parameters.

Description:

- The iwis CLA lubrication pump is properly connected to an external controller via the electrical interface and connected to the power supply.
- If the supply voltage is too low, the iwis CLA lubrication pump sends a permanent output signal as low level (0 V) to PIN 4 for external control (PLC).
- Check the supply voltage and compare it with the parameters given in the iwis CLA lubrication pump technical data
- Error E3 (undervoltage) must be acknowledged with the control signal 14 seconds (chapter 7.4.5.) after elimination of the cause(s).

i The iwis CLA lubrication pump does not process control signals until all errors have been eliminated.

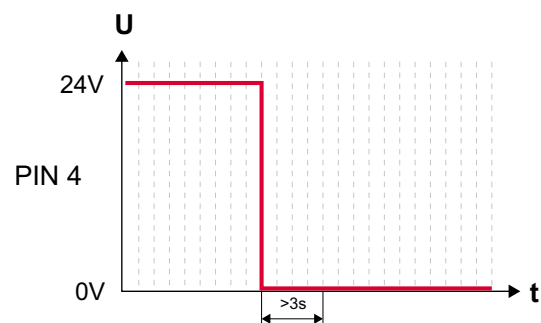

Operating Instructions: CLA Lubrication System

7.5.4. Critical error

The critical error indicates that the integrated micro-electronics has detected a critical error and that the iwis CLA lubrication pump is not operating within the valid parameters. The cause can be mechanical, electronic or any other influencing variable.

Description:

The iwis CLA lubrication pump is properly connected to an external controller via the electrical interface and connected to the power supply.

- In an (internal) diagnosis, the critical (exception) error E4 has been detected.
- Error E4 cannot be rectified by you on site and cannot be acknowledged by you on the iwis CLA lubrication pump.
- If this does not correct the E4 error, dismantle the iwis CLA lubrication pump and send it back to the manufacturer together with the lubricant cartridge and a description of the error. The address of the manufacturer is given in chapter I.II.

i Do not open the iwis CLA lubrication pump without authorization! Observe the relevant notes and regulations in these instructions for proper use (section 2.5) and warranty (section 2.6)!

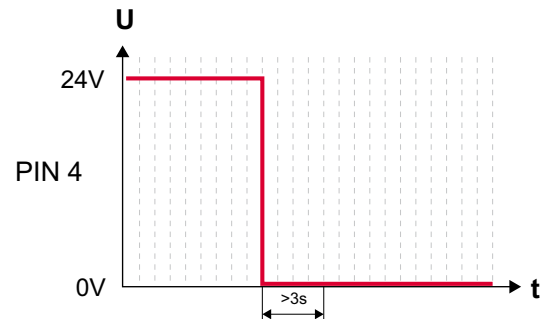

Operating Instructions: CLA Lubrication System

8. Operation and settings – time-controlled version (TC)

8.1. General information

- i** In order to use the iwis CLA lubrication pump, it must first be properly mounted and installed and then switched on. The assembly is very simple and described in detail in chap. 6.2.

What you should know about operating and setting the time controlled (TC) iwis CLA Lubrication Pump:

- The iwis CLA lubrication pump is suitable as a multi-point lubricator for one or two lubrication points. However, depending on the specific application, iwis CLA lubrication pump can also supply a limited number of lubrication points reliably and cleanly with lubricant. Accessories from the manufacturer (e. g. distributors or progressive distributors) can be connected to the iwis CLA lubrication pump. If necessary, changes must be made to the iwis CLA lubrication pump settings to ensure safe and reliable operation.
- The iwis CLA lubrication pump is a cycle controlled lubricator, which works time-based via the integrated micro-electronics and is connected to a 24V DC power supply. The iwis CLA lubrication pump cyclically delivers a defined quantity of lubricant from the cartridge to the outlet. Three operation modes can be selected. The **Hour-Mode -h-** allows setting the number of cycles (c) within a dispensing time (h) in hours. The cycles (c) are evenly distributed over the dispensing time. Dispensing times (h) between 1...240 hour(s) and cycles (c) between 1...30 can be set. The **Empty-Time-Mode Et** allows the emptying time of the cartridge to be set in months. Emptying times between 1...36 month(s) and cycles (c) between 1... 30 can be set. Alternatively, the iwis CLA pump can also be integrated into a control system (PLC) and commanded and controlled in **pulse mode PUL** and controlled by it, see chap. 8.5.
- A dispensing cycle consists of at least one (1) donation (stroke) and can consist of a maximum of thirty (30) donations (strokes). Up to thirty (30) donations (strokes) per outlet are made in direct succession. After the end of the lubrication cycle, the iwis CLA lubrication pump rests until the set break time time h has elapsed and automatically carries out the next lubrication cycle after the set break time time h has elapsed.
- The respective conditions of the iwis CLA lubrication pump can be seen in the LCD, which additionally enables the optical recognition of the condition by means of coloured LEDs.

8.2. Factory settings

The iwis CLA lubrication pump is always delivered ex works with the following settings:

Operation mode	Hour-Mode -h-
State	OFF iwis CLA lubrication pump is switched off

- i** The factory settings foresee using the iwis CLA lubrication pump in the **Hour-Mode -h-**. If you want to operate the iwis CLA lubrication pump in **Empty-Time-Mode Et** or **Pulse-Control-Mode PUL**, you have to make changes in the SET-Menu of the iwis CLA lubrication pump.

Operating Instructions: CLA Lubrication System

8.2.1. Default settings Hour-Mode -h-

Pause time $h = 3$ The break time time is 3 hours.
 Number of cycles $c = 1$ The number of cycles is one (1) stroke after the break time time.

- i** The default settings in the Hour-Mode when using a iwis CLA lubrication pump with one (1) lubricant outlet result in an emptying time (service life) of 333 days (= 11 months) for a full 400ml lubricant cartridge, provided that the iwis CLA lubrication pump is permanently switched on and no special dispensations have been made. Within approx. 3 hours, the iwis CLA lubrication pump will deliver one donation per stroke (0.15 cm³).
- i** If you use the iwis CLA lubrication pump with one (1) lubricant outlet, a dispensing stroke will be delivered from one outlet at the end of the break time time. If you are using the iwis CLA lubrication pump with two (2) lubricant outlets, one delivery of one stroke per outlet will be delivered at the end of the break time.

Verify that the default settings are appropriate for your application and that the lubrication point is supplied with the correct amount of lubricant per time unit. If this is the case, you can operate the iwis CLA lubrication pump with the default settings in the Hour-Mode -h-. If this is **not** the case, change the values for the dispensing time h and number of cycles c accordingly.

8.2.2. Default settings Empty-Time-Mode Et

Emptying time $Et = 6$ The emptying time of one (1) cartridge is 6 months.
 Number of cycles $c = 1$ The number of cycles is one (1) stroke during the dispensing time.

- i** The default settings in the Empty-Time-Mode result in an emptying time (service life) of 6 months for a full 250ml lubricant cartridge, provided that the iwis CLA lubrication pump is permanently switched on and no special dispensations have been made. When using a 400ml cartridge, the iwis CLA lubrication pump will deliver a single stroke (0.15 cm³) of the dispenser within approximately 1,6 hours.
- i** If you use the iwis CLA lubrication pump with one (1) lubricant outlet, a dispensing stroke will be delivered from one outlet at the end of the break time time. If you are using the iwis CLA lubrication pump with two (2) lubricant outlets, one delivery of one stroke per outlet will be delivered at the end of the break time.

Verify that the default settings are appropriate for your application and that the lubrication point is supplied with the correct amount of lubricant per time unit. If this is the case, you can operate the iwis CLA lubrication pump with the default settings in the Empty-Time-Mode Et. If this is **not** the case, change the values for the emptying time t accordingly; see chapter (Kap. 3.8.9)



Operating Instructions: CLA Lubrication System

8.3. Menu and LCD messages

The LCD of the iwis CLA lubrication pump can be used to read information optically, to change settings in conjunction with the activation and programming key on the underside of the iwis CLA lubrication pump, or to trigger individual actions.

In principle, settings can be changed and actions triggered both when the iwis CLA lubrication pump is switched off (OFF) and when it is switched on (ON). The individual submenus are presented, described and explained in detail in chapters 6.3.4 to 6.3.10.

The symbolic representations used below are described as follows:

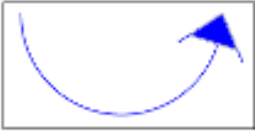
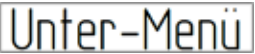
Symbol	Description	Note / Detail
	LCD Display	The LCD displays information both during operation and for programming purposes.
	Sequence arrow	The black sequence arrow indicates the unchangeable basic structure of the menu.
	Action arrow	The blue action arrow shows the sequence of touching the action area with the activation and programming key once.
	Sub-Menu	In the respective submenus information can be read, dispensing processes can be initiated and settings can be changed.

- i** The iwis CLA lubrication pump can be switched on and off at several points in the menu navigation. For details see chapter 8.3.3.

Operating Instructions: CLA Lubrication System

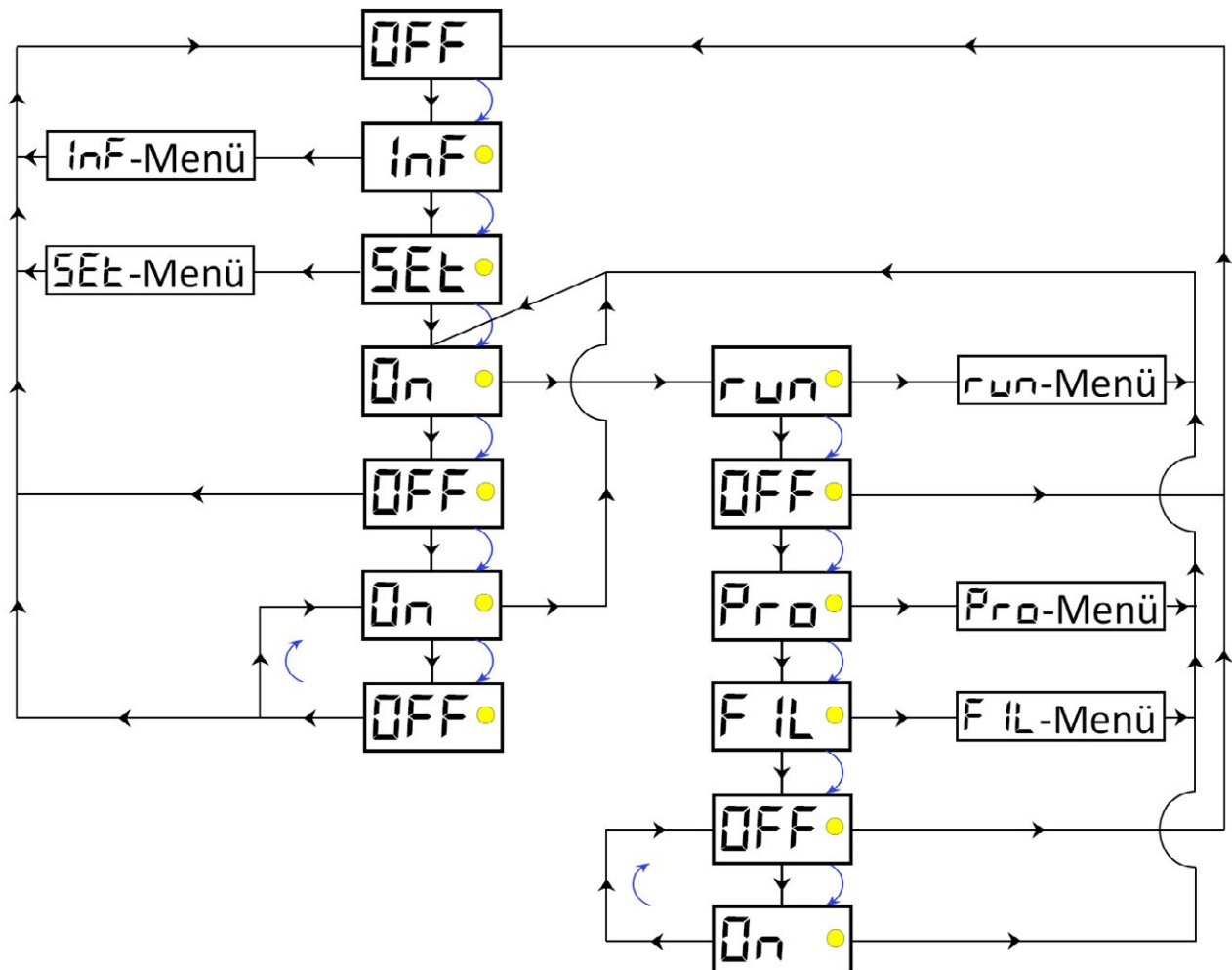





The graphic above illustrates the unchangeable basic flowchart of the iwis CLA lubrication pump menu navigation as well as the options for branching to the Sub- Menus.

- i** The INF-Menu can only be accessed from the OFF mode (iwis CLA lubrication pump is switched off). The INF-Menu provides you with an informative overview of the current iwis CLA lubrication pump settings. For details see chapter 8.3.4.
- i** The SET-Menu can only be accessed from the OFF mode (iwis CLA lubrication pump is switched off). The SET-Menu allows you to make changes to the operating mode. Details can be found in chapter 8.3.6.
- i** The RUN-Menu can only be accessed from the ON mode (iwis CLA lubrication pump is switched on). The RUN-Menu allows you to manually trigger a single donation at the iwis CLA lubrication pump. For details see chapter. 8.3.7.
- i** The PRO-Menu is only accessible from the ON mode (iwis CLA lubrication pump is switched on). The PRO-Menu allows you to make changes to the iwis CLA lubrication pump settings - and thus to its dispensing behavior. For details see chapter 8.3.8 or 8.3.9.
- i** The FIL-Menu is only accessible from the ON mode (iwis CLA lubrication pump is switched on). The FIL menu allows you to manually trigger a fixed number of donations to the iwis CLA lubrication pump. For details see chapter 8.3.10.

Operating Instructions: CLA Lubrication System

8.3.1. LCD

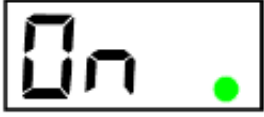
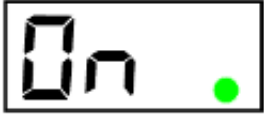
For optical output, information in the various states is displayed on the LCD via iwis CLA lubrication pump. You will be supported by three coloured LEDs to the right of the LCD, depending on the state of the iwis CLA lubrication pump. This allows you to assess the condition of the iwis CLA lubrication pump from a distance; the following applies: green: OK; red: Error. The following tables show the LED assignment on the LCD as well as the explanation of the respective output:

Assignment (graphic)	Assignment (in words)	
	upper LED: red medially LED: yellow lower LED: green	
LCD	Description	Naming
	The red LED only lights up if there is an error. The iwis CLA lubrication pump must be ON before the error occurs.	Error with the iwis CLA lubrication pump
	The yellow LED only lights up if the activation and programming key has touched the action surface (activation and programming key detected).	Activation and programming key detected by iwis CLA lubrication pump
	The green LED lights up during a dispensing process for approx. 10...18 seconds.	iwis CLA lubrication pump dispenses lubricant
	The green LED lights up when changes are possible and the activation and programming key was previously detected.	Changes possible
	The green LED flashes every 5 seconds when iwis CLA lubrication pump is ON and there is no error.	iwis CLA lubrication pump is ready for use
	The green LED flashes 2x when a value has been confirmed. In addition to the green LED, the LCD also flashes 2x.	Acceptance of changed value

Operating Instructions: CLA Lubrication System

Display in LCD	Meaning
dark	Power supply not connected
OFF	iwis CLA lubrication pump is switched off
On	iwis CLA lubrication pump is ready for operation; iwis CLA lubrication pump dispenses lubricant in accordance to the operation mode and the set values
PUL	iwis CLA lubrication pump is ready for operation in the pulse mode PUL and waiting for a control signal from the external control system (PLC)
PUL (blinking)	iwis CLA lubrication pump receives a control signal from the external control (PLC)
---	Received control signal longer than 15 sec.

Errors

E1	Error E1 (Empty Cartridge)
E2	Error E2 (Overload)
E3	Error E3 (Undervoltage)
E4	Error E4 (Fatal error)

Sub-Menu

INF	INF-Menu
n41	Firmware version of the iwis CLA lubrication pump
h03	Currently set value of the break time time h
c01	Currently set value of the number of cycles c
06	Currently set value of the emptying time Et
PUL	Currently Pulse-Control-Mode is set
SET	SET-Menu
-h-	Operating mode Hour-Mode
Et	Operating mode Emptying-Time-Mode
PUL	Operating mode Pulse-Control-Mode
250 / 400	Adjustable value of the cartridge size (iwis CLA only available in 400ml)
RUN	RUN-Menu
01...70	During the manually triggered active RUN command ("Quick-Check"/special donation), the LCD displays the approximate back pressure in bar. In addition, the green LED lights up.
Clr	If the process is aborted during the FIL command, Clr appears first.

Additional character on the LCD

MAX	After each cycle the maximum back pressure is displayed in bar.
1 / 2	During a dispensing process, the iwis CLA lubrication pump indicates from which outlet lubricant is being pumped.

Operating Instructions: CLA Lubrication System

8.3.2. Actions with the activation and programming key

The activation and programming key attached to the housing of the iwis CLA lubrication pump allows you to perform actions and changes in the settings of the iwis CLA lubrication pump. This activation and programming key can be easily and permanently stored on the iwis CLA lubrication pump.

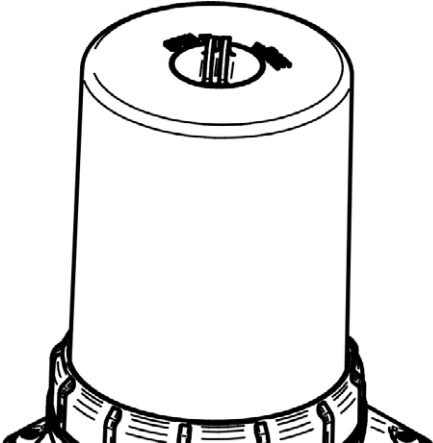
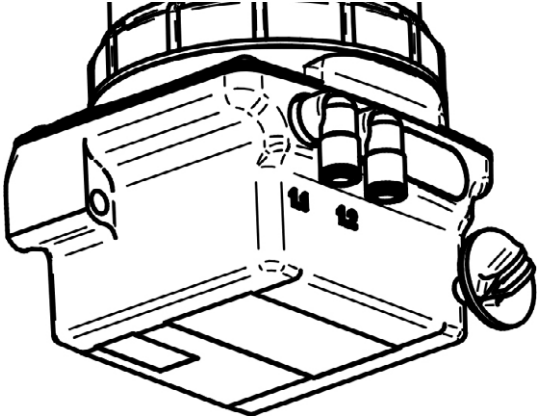
	<p>1. Remove the activation and programming key.</p> <p>Turn the activation and programming key to the OPEN position and remove it from the housing of the iwis CLA lubrication pump.</p> <p>i The activation and programming key is stored in the opening on the top of the housing of the iwis CLA lubrication pump. It is also used to seal the iwis CLA lubrication pump.</p>
	<p>2. Guide the activation and programming key to the action area.</p> <p>Place the activation and programming key on the action area on the front of the iwis CLA lubrication pump.</p> <p>As soon as the activation and programming key on the action area has been detected by iwis CLA lubrication pump, the yellow LED in the LCD lights up. The menu runs in a rhythm of approx. 2 seconds.</p> <p>Remove the activation and programming key from the action area as long as the desired menu item is displayed in the LCD. The yellow LED disappears. You have performed an action. The LCD flashes together with the green LED twice.</p>

At the end of the action or settings, insert the activation and programming key again into the hole provided on the housing of the iwis CLA lubrication pump. Then turn the activation and programming key to the CLOSE position to restore the sealing effect.

- i** Please note, however, that in the event of faults or changes to be made, no changes or actions can be carried out on the iwis CLA lubrication pump without the activation and programming key. If you do not reattach the activation and programming key to the housing of the iwis CLA lubrication pump after carrying out actions on the iwis CLA lubrication pump, there is no separation from the environment and dirt can get into the housing. The activation and programming key must be remounted in the housing of the iwis CLA lubrication pump after actions have been performed.

Operating Instructions: CLA Lubrication System

8.3.3. Switching on and off

Switch the iwis CLA lubrication pump on:

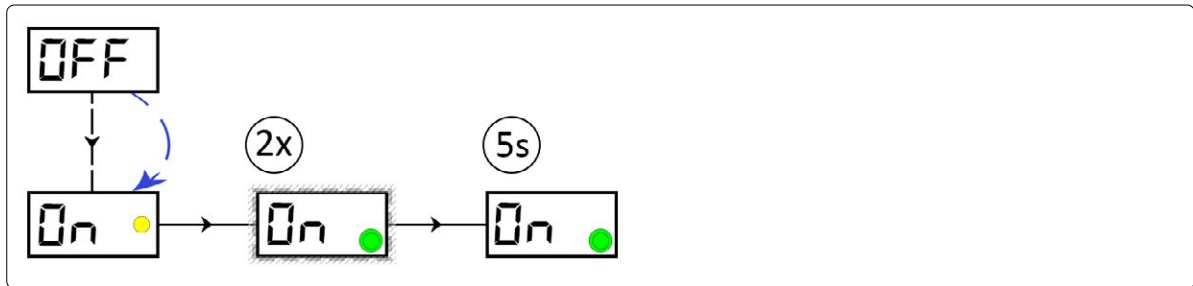

iwis CLA lubrication pump is switched off (OFF).

- Hold the activation and programming key on the action area. The yellow LED lights up. Leave the activation and programming key on the action area until ON is displayed in the LCD.
- Remove the activation and programming key from the action area as long as ON is displayed in the LCD. The yellow LED disappears; the LCD flashes together with the green LED twice.

If no error is detected during the iwis CLA lubrication pump self-check, ON is displayed in the LCD. The green LED lights up once every 5 seconds, iwis CLA lubrication pump is ready for operation and will dispense lubricant according to the set values.

- Insert the activation and programming key into the hole provided on the underside of the iwis CLA lubrication pump.

Switch the iwis CLA lubrication pump off:

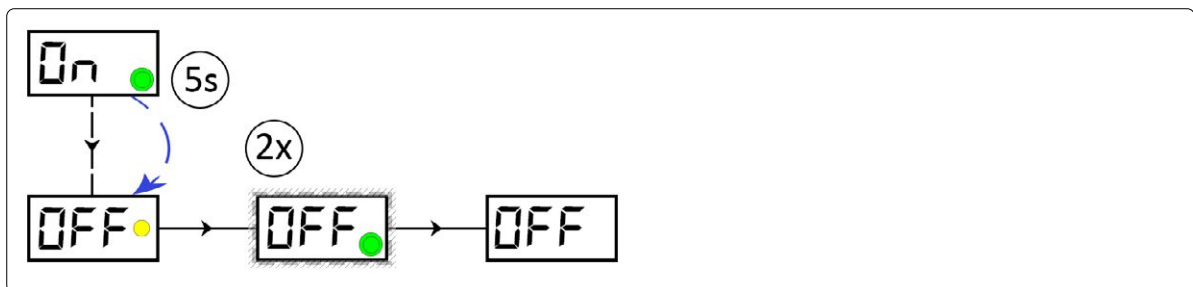

iwis CLA lubrication pump is ON, the green LED flashes every 5 seconds.

- Hold the activation and programming key on the action area. The yellow LED lights up. Leave the activation and programming key on the action area until OFF is displayed in the LCD.
- Remove the activation and programming key from the action area as long as OFF is displayed in the LCD. The yellow LED disappears; the LCD flashes together with the green LED twice.

iwis CLA lubrication pump is OFF; OFF appears in the LCD. iwis CLA lubrication pump stops dispensing lubricant.

- Insert the activation and programming key into the hole provided on the underside of the iwis CLA lubrication pump.

i iwis CLA lubrication pump can be switched off in any state (normal operating state or error) in the manner described here.

Operating Instructions: CLA Lubrication System

8.3.4. INF-Menu Hour-Mode -h-

The INF-Menu is used to inform the user about the firmware used in the iwis CLA lubrication pump and the settings made and currently active (values of the adjustable variables h and c that can be changed in the PRO-Menu). In the INF-Menu nothing can be changed by the user. The values of the parameters are displayed in a fixed order.changed in the PRO-Menu).

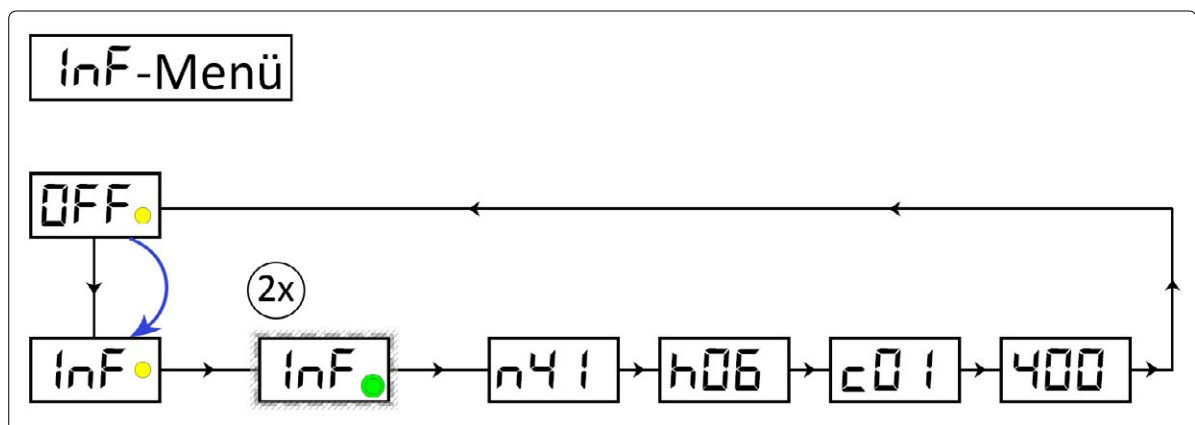

n	Alphanumerical name of the iwis CLA lubrication pump firmware
h	set value of variable h break time in hours
c	set value of variable c number of cycles
400	value of the size of the lubricant cartridge (for iwis CLA only 400ml possible)

- Remove the activation and programming key from the housing of the iwis CLA lubrication pump and place it on the action area.
- Hold the activation and programming key on the action area. The yellow LED lights up. Leave the activation and programming key on the action area until INF is displayed in the LCD.
- Remove the activation and programming key from the action area as long as INF is displayed in the LCD. The yellow LED disappears; the LCD flashes together with the green LED twice.

iwis CLA lubrication pump informs you optically on the LCD about the set values.

- Insert the activation and programming key into the hole provided on the underside of the iwis CLA lubrication pump.

- i** The INF-Menu can only be accessed from the OFF mode (iwis CLA lubrication pump is switched off). When you have entered the INF-Menu, you will return to the OFF mode.

Operating Instructions: CLA Lubrication System

8.3.5. INF-Menu operating mode Empty-Time-Mode Et

The INF-Menu is used to inform the user about the firmware used in the iwis CLA lubrication pump and the settings made and currently active (value of the adjustable variable Et that can be changed in the PRO-Menu).

In the INF-Menu nothing can be changed by the user. The values of the parameters are displayed in a fixed order.

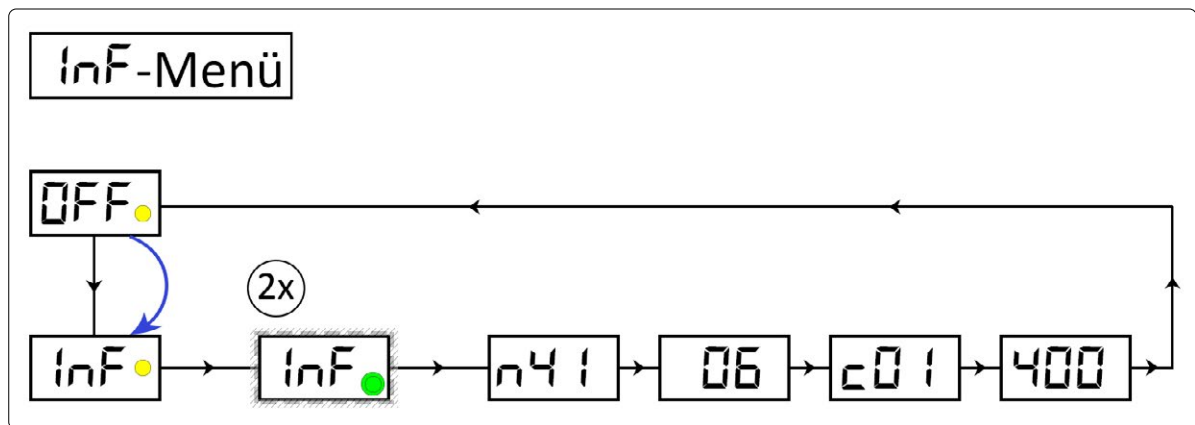

n	Alphanumerical name of the iwis CLA lubrication pump firmware
Et	set value of the variable Et emptying time in months
c	set value of variable c number of cycles
400	value of the size of the lubricant cartridge (for iwis CLA only 400ml possible)

- Remove the activation and programming key from the bottom of iwis CLA lubrication pump and place it on the action area.
- Hold the activation and programming key on the action surface. The yellow LED lights up. Leave the activation and programming key on the action area until INF is displayed in the LCD.
- Remove the activation and programming key from the action area as long as INF is displayed in the LCD. The yellow LED disappears; the LCD flashes together with the green LED twice.

iwis CLA lubrication pump informs you optically on the LCD about the set values.

- Insert the activation and programming key into the hole provided on the underside of the iwis CLA lubrication pump.

- i** The INF-Menu can only be accessed from the OFF mode (iwis CLA lubrication pump is switched off). When you have entered the INF-Menu, you will return to the OFF mode.

Operating Instructions: CLA Lubrication System

8.3.6. SET-Menu

The SET-Menu allows you to change the operating mode and the size of the used cartridge of the iwis CLA lubrication pump. You can switch between Hour-Mode -h-, Empty-Time-Mode Et. Impulsmodus PUL wechseln. The Hour-Mode -h- allows you to set the number of cycles (c) after a break time time (h) in hours. The Empty-Time-Mode Et allows you to set the emptying time (Et) of the cartridge in months. Cycles (c) and break time time (h) or emptying time (Et) can be adjusted after selecting the operating mode in the PRO menu. The pulse mode PUL enables after the integration into a control system (PLC) or similar, command and control by the control system (PLC). Cycles (c) and pause time (h) or the discharge time (Et) can be adjusted after selecting the operating mode in the PRO Menu.

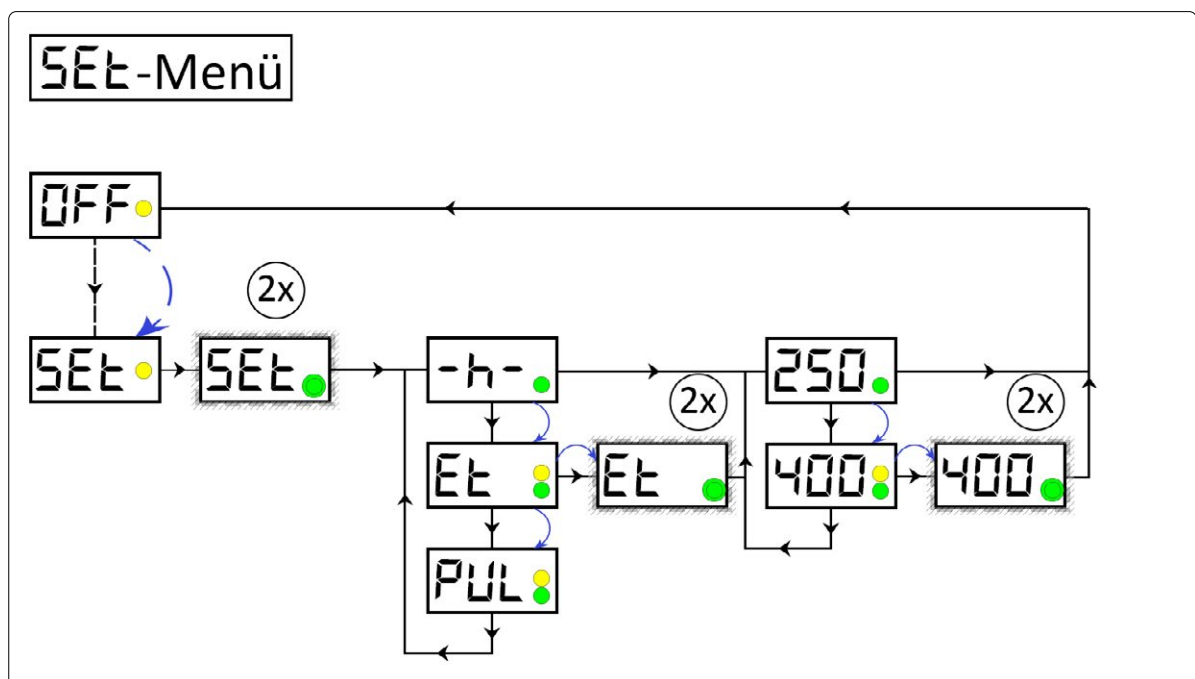

-h- Operating mode Hour-Mode

Et Operating mode Empty-Time-Mode

PUL Betriebsmodus Impulsmodus

250/400 Changeable parameter of the cartridge size (for iwis CLA only 400ml possible)

iwis CLA lubrication pump is switched off (OFF).

- Remove the activation and programming key from the bottom of iwis CLA lubrication pump and place it on the action area.
- Hold the activation and programming key on the action surface. The yellow LED lights up. Leave the activation and programming key on the action area until SET is displayed in the LCD.
- Remove the activation and programming key from the action area.

The yellow LED disappears; the LCD flashes together with the green LED twice. The LCD displays the currently set operating mode. You now have the option of changing the operating mode.

Operating Instructions: CLA Lubrication System

Changing the operating mode:

- If you want to change the operating mode, move the activation and programming key back to the action area.

The yellow LED lights up and the LCD displays the currently unselected operating mode. The yellow LED lights up as long as the activation and programming key is on the action surface; the two adjustable operating modes run alternately.

- When your desired operating mode is displayed on the LCD, remove the activation and programming key from the action area.

The yellow LED disappears; the LCD flashes together with the green LED twice. The selected operating mode has now been accepted.

Not changing the operating mode:

- If you do not want to change the operating mode, the activation and programming key must remain removed from the action area.

The LCD flashes together with the green LED twice, whereby the operating mode is displayed in the LCD.

The LCD now displays the currently set value of the cartridge size. Now you have the possibility to change the value of the used cartridge size.

Changing the used cartridge size:

- If you want to change the cartridge size, move the activation and programming key back to the action area.

The yellow LED lights up and the LCD displays the currently unselected cartridge size. The yellow LED lights up as long as the activation and programming key is on the action surface; the two adjustable cartridge sizes run alternately.

- When your desired cartridge size is displayed on the LCD, remove the activation and programming key from the action area.

i The iwis CLA pump is only available with a cartridge size of 400ml.

Not changing the cartridge size:

- If you do not want to change the cartridge size, the activation and programming key must remain removed from the action area.

The LCD flashes together with the green LED twice, whereby the cartridge size is displayed in the LCD.

i The SET-Menu can only be accessed from the OFF mode (iwis CLA lubrication pump is switched off).
When you have entered the SET-Menu, you will return to the OFF mode.

i Before commissioning, check that the correct cartridge size is set in the iwis CLA lubrication pump software.
The cartridge size used and the cartridge size set in the software must be identical!

i The iwis CLA pump is only available with a cartridge size of 400ml.

Operating Instructions: CLA Lubrication System

8.3.7. RUN-Menu

The RUN-Menu is used for manual activation of the iwis CLA lubrication pump. A special donation from iwis CLA lubrication pump can be triggered in this way. This function can, for example, be used for the advantageous „Quick Check“ to manually check the condition of the lubrication point.

iwis CLA lubrication pump carries out a special donation after triggering the RUN function. After triggering the RUN function, the iwis CLA lubrication pump executes exactly as many strokes per outlet as were set in the variable number of cycles c in the PRO menu. During the stroke, the back pressure detected by the integrated microelectronics is displayed in the LCD as an approximate value in bar.

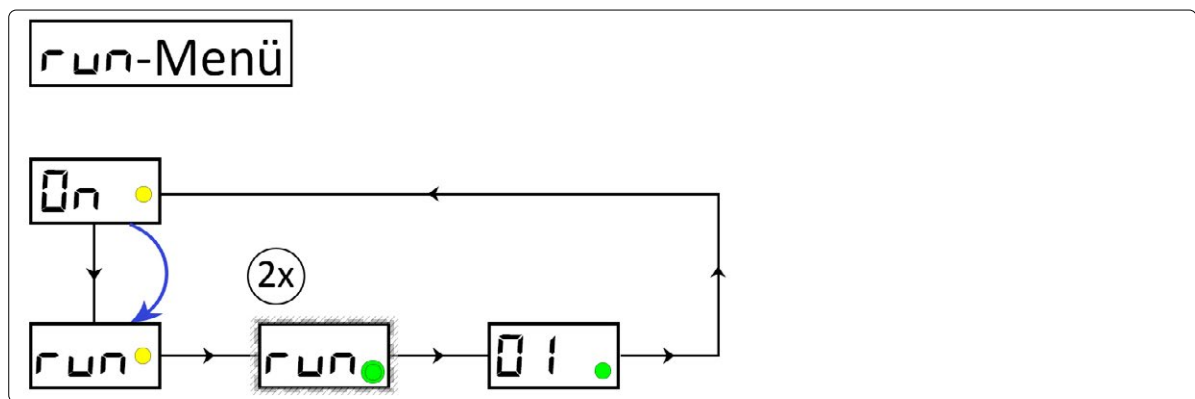

There is no fault or error at iwis CLA lubrication pump.

- Remove the activation and programming key from the housing of the
- iwis CLA lubrication pump and place it on the action area.
- Hold the activation and programming key on the action area. The yellow LED lights up. Leave the activation and programming key on the action area until RUN is displayed in the LCD. Remove the activation and programming key from the action area as long as RUN is displayed in the LCD. The yellow LED disappears.

The LCD flashes together with the green LED twice. The iwis CLA lubrication pump starts to pump the lubricant to the outlet (special donation or „Quick-Check“).

- Insert the activation and programming key into the hole provided on the housing of the iwis CLA lubrication pump or repeat the special dispenser („Quick-Check“) if necessary.
- Observe the back pressure values displayed on the LCD if they are of interest to you.

- i** During the dispensing process, the green LED lights up; in addition, the counterpressure for the stroke is displayed in the LCD.
- i** If you use the RUN function in the Emptying-Time-Mode, the Emptying time is reduced.
- i** The RUN-Menu can only be reached from the ON mode (iwis CLA lubrication pump switched on). When you have entered the RUN-Menu, you will return to the ON mode

Operating Instructions: CLA Lubrication System

8.3.8. PRO-Menu operating mode Hour-Mode -h-

The PRO-Menu allows you to change the settings of the iwis CLA lubrication pumps dispensing behavior. You can change the break time time h as well as the number of cycles c (number of strokes). The basic rule is that during a dispensing cycle the iwis CLA lubrication pump performs exactly the number c of strokes (each 0.15 cm^3) specified in the number c of cycles. The dispensing cycle repeats itself after the number of hours specified in the break time time h .

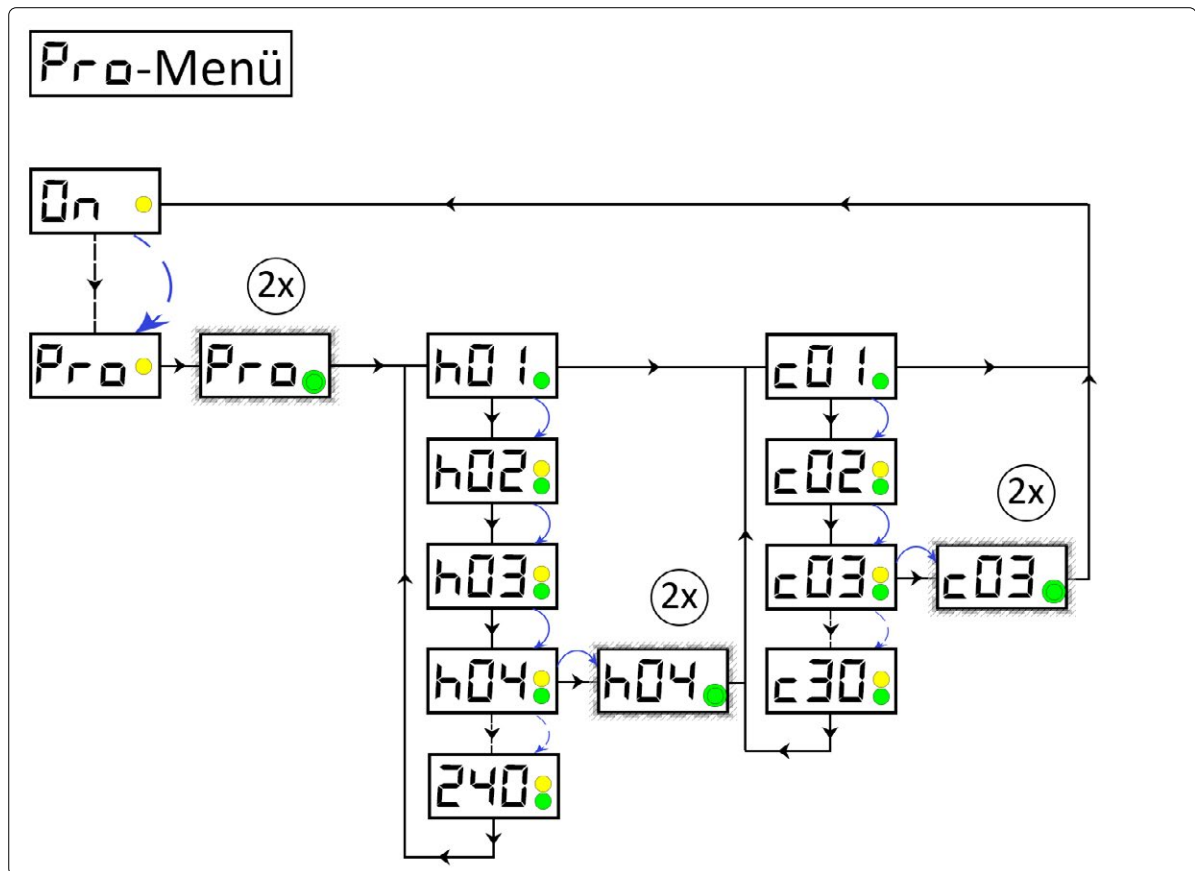

There is no fault or error at iwis CLA lubrication pump.

In the PRO menu, the first step is to set the break time time h and afterwards the number of cycles c ; direct access to the number of cycles c is not possible.

- Remove the activation and programming key from the housing of iwis CLA lubrication pump and place it on the action area. Hold the activation and programming key on the action surface. Leave the activation and programming key on the action area until PRO is displayed in the LCD.
- Remove the activation and programming key from the action area.

The LCD flashes together with the green LED twice. The LCD first displays the currently set value of the break time time h (h_i). Now you have the possibility to change the values of the break time time h .

Operating Instructions: CLA Lubrication System

Changing the value of the break time time h:

- If you want to change the value of the break time time h, move the activation and programming key back to the action area.

In the LCD the next higher ($h_{is} + 1$) adjustable value of the break time time h is displayed. The green LED lights up as long as the activation and programming key is on the action surface; the other values of the break time time h run through one after the other. However, you can also remove the activation and programming key from the action area and bring it back to the action area shortly afterwards to reach each value one after the other. If the final value of the break time time h of $h=240$ is reached and no value has been selected, the menu returns to $h=01$ and the cycle can be restarted.

- As long as the new value you choose for the break time time h (h_{new}) is displayed in the LCD, remove the activation and programming key from the action area.

The yellow LED disappears, the green LED and the LCD flash 2x. The selected new value ($h_{new} = h_{is}$) of the break time time h has now been accepted. The submenu will now automatically take you to the values of the number of cycles c.

No changing of the value of the break time time h:

- If you do not want to change the value of the break time time h, the activation and programming key must remain removed from the action area immediately after entering the PRO-Menu.
- The LCD as well as the green LED flashes twice and the break time time h is displayed in the LCD. The submenu now automatically takes you to the values of the number of cycles.

The LCD now displays the currently set value of the number of cycles c (c_{is}). Now you have the possibility to change the values of the number of cycles c.

Changing of the value of the number of cycles c:

- If you want to change the value of the number of cycles c, move the activation and programming key back to the action area.

In the LCD the next higher ($c_{is} + 1$) adjustable value of the number of cycles c is displayed. The yellow LED lights up as long as the activation and programming key is on the action surface; the other values of the number of cycles c run through one after the other. However, you can also remove the activation and programming key from the action area and bring it back to the action area shortly afterwards to reach each value one after the other. If the final value of the number of cycles c of $c=30$ is reached and no value has been selected, the menu returns to $c=01$ and the cycle can be restarted

- As long as the new value you choose for the number of cycles c (c_{new}) is displayed in the LCD, remove the activation and programming key from the action area.

The yellow LED disappears, the green LED and the LCD flash 2x. The selected new value ($c_{new} = c_{is}$) of the break time time h has now been accepted.

Operating Instructions: CLA Lubrication System

No changing of the value of the number of cycles c:

- If you do not want to change the value of the number of cycles c, the activation and programming key must remain removed from the action area immediately after entering the PRO-Menu.

The LCD as well as the green LED flashes twice and the number of cycles c is displayed in the LCD.

- Reattach the magnet pin in the opening provided on the upper part of the iwis CLA lubrication pump.

i The PRO-Menu can only be reached from the ON mode (iwis CLA lubrication pump switched on). When you enter the PRO-Menu, you will return to the ON mode.

i If you have made changes to the values of the break time time h or the values of the number of cycles c in the PRO-Menu and the iwis CLA lubrication pump is otherwise ready for operation (cartridge fitted), the iwis CLA lubrication pump will immediately start with the calculated waiting time until the next break time.

- Observe the back pressure values displayed on the LCD if they are of interest to you.

i During the break time process, the green LED lights up; in addition, the counterpressure for the stroke is displayed in the LCD.

The parameters that can be set for the break time time h and the number of cycles c and their respective permissible values are specified as follows:

h := **Pause time** in hours (h).

The dispensing time can be set between 1 | 2 | 3 | ... | 240 hours.

Values of 1 | ... | 99 are displayed in the LCD with h in front, values of 100 | ... | 240 without h in front.

The time counter integrated in the iwis CLA lubrication pump microelectronics starts counting the break time time h after a successful and completed dispensing cycle.

c := **Number of cycles** within a dispensing cycle (c).

The number of cycles c can be set between 1 | 2 | 3 | ... | 30 strokes.

Operating Instructions: CLA Lubrication System

Changing the value of the emptying time Et:

- If you want to change the value of the emptying time Et, move the activation and programming key back to the action area.

In the LCD the next higher ($E_{t_{is}} + 1$) adjustable value of the emptying time Et is displayed. The yellow LED lights up as long as the activation and programming key is on the action surface; the other values of the emptying time Et run through one after the other. However, you can also remove the activation and programming key from the action area and bring it back to the action area shortly afterwards to reach each value one after the other. If the final value of the emptying time Et of $E_t=36$ is reached and no value has been selected, the menu returns to $E_t=01$ and the cycle can be restarted.

- As long as the new value you choose for the emptying time Et ($E_{t_{new}}$) is displayed in the LCD, remove the activation and programming key from the action area.

The yellow LED disappears, the green LED and the LCD flash 2x. The selected new value ($E_{t_{new}} = E_{t_{is}}$) of the dispensing time h has now been accepted.

No changing of the value of the emptying time Et:

- If you do not want to change the value of the emptying time Et, the activation and programming key must remain removed from the action area immediately after entering the PRO-Menu.

The LCD as well as the green LED flashes twice and the emptying time Et is displayed in the LCD. Now you have the possibility to change the values of the number of cycles c.

Changing the value of the number of cycles c:

- If you want to change the value of the number of cycles c, move the activation and programming key back to the action area.

In the LCD the next higher ($c_{is} + 1$) adjustable value of the number of cycles c is displayed. The yellow LED lights up as long as the activation and programming key is on the action surface; the other values of the number of cycles c run through one after the other. However, you can also remove the activation and programming key from the action area and bring it back to the action area shortly afterwards to reach each value one after the other. If the final value of the number of cycles c of $c=30$ is reached and no value has been selected, the menu returns to $c=01$ and the cycle can be restarted.

- As long as the new value you choose for the number of cycles c (c_{new}) is displayed in the LCD, remove the activation and programming key from the action area.

The yellow LED disappears, the green LED and the LCD flash 2x. The selected new value ($c_{new} = c_{is}$) of the number of cycles c has now been accepted.

Operating Instructions: CLA Lubrication System

No changing of the value of the number of cycles c:

- If you do not want to change the value of the number of cycles c, the activation and programming key must remain removed from the action area immediately after entering the PRO-Menu.

The LCD as well as the green LED flashes twice and the number of cycles c is displayed in the LCD.

- Insert the activation and programming key into the hole provided on the housing of the iwis CLA lubrication pump.

i The PRO-Menu can only be reached from the ON mode (iwis CLA lubrication pump switched on).
When you enter the PRO-Menu, you will return to the ON mode.

i If you have made changes to the values of the break time time h or the values of the number of cycles c in the PRO-Menu and the iwis CLA lubrication pump is otherwise ready for operation (cartridge fitted), the iwis CLA lubrication pump will immediately start with the calculated waiting time until the next break time

- Observe the back pressure values displayed on the LCD if they are of interest to you.

i During the break time process, the green LED lights up; in addition, the counterpressure for the stroke is displayed in the LCD.

The parameters that can be set for the Emptying time Et and the number of cycles c and their respective permissible values are specified as follows:

Et := **Emptying time** of a full cartridge in months (Et).

The emptying time can be set between 1 | 2 | 3 | ... | 36 months.

The time counter integrated in the microelectronics of the iwis CLA lubrication pump starts counting the break time time at the end of a successful and fully completed dispensing cycle

c := **Cycles** (Frequency of strokes) within the Emptytime Et

Die Zyklenzahl c kann zwischen 1 | 2 | 3 | ... | 30 Hübe eingestellt werden.

Operating Instructions: CLA Lubrication System

8.3.10. FIL-Menu

The FIL-Menu allows you to trigger a defined multiple donation to iwis CLA lubrication pump. A total of 40 pump strokes are initiated with the activation. This function enables you to prefill connected accessories (tubes, distributors, etc.) with the lubricant contained in the lubricant cartridge, especially during the initial start-up of iwis CLA lubrication pump. However, the process can also be aborted manually at any time.

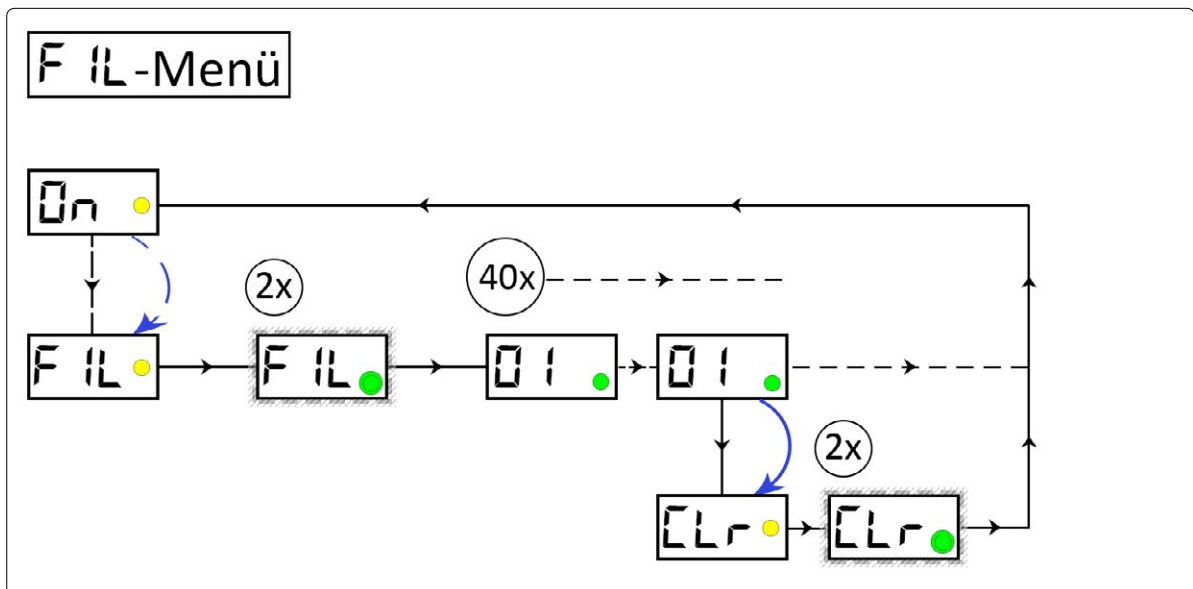

There is no fault or error at iwis CLA lubrication pump.

- Remove the activation and programming key from the housing of the iwis CLA lubrication pump and place it on the action area.

The yellow LED will light up. Leave the activation and programming key on the action area until FIL is displayed in the LCD. Remove the activation and programming key from the action area. The yellow LED disappears.

- The LCD flashes together with the green LED twice. The iwis CLA lubrication pump starts donating. The green LED lights up during each donation.
- If you do not want to cancel the process: Insert the activation and programming key into the hole provided on the housing of the iwis CLA lubrication pump.

iwis CLA lubrication pump dispenses 40 strokes of lubricant.

- If you want to cancel the process: Place the activation and programming key on the action area and wait until the end of a dispensing process (motor run).

CLR appears in the LCD.

- Remove the activation and programming key from the action area.

iwis CLA lubrication pump stops the FIL command.

- Observe the back pressure values displayed on the LCD if they are of interest to you.

i During the dispensing process, the green LED lights up; in addition, the counterpressure for the stroke is displayed in the LCD.





i If you use the FIL function in the Emptying-Time-Mode, the Emptying time is reduced.

i The FIL-Menu can only be reached from the ON mode (iwis CLA lubrication pump switched on).
When you enter the FIL-Menu, you will return to the ON mode.

Operating Instructions: CLA Lubrication System

8.4. Error codes

The microelectronics integrated in the iwis CLA lubrication pump permanently monitors the status. In the event of irregularities, an addressed error message is displayed on the LCD. The red LED flashes every 5 seconds and also signals an error optically.

LCD	Name	Description	Remedy
	Error E1	Cartridge empty	<ul style="list-style-type: none"> • Refill lubricant in the iwis CLA Lubrication Pump. • i No confirmation of the error necessary; it is automatically cleared after the remedial action.
	Error E2	Overload; the back pressure at the lubrication point is too high	<ul style="list-style-type: none"> • Check the lubrication point and eliminate the cause of the fault. • Switch iwis CLA lubrication pump off (OFF) and on (ON) again.
	Error E3	Undervoltage	<ul style="list-style-type: none"> • Switch iwis CLA lubrication pump off (OFF). • Check the power supply. • Switch iwis CLA lubrication pump on (ON).
	Error E4	Fatal error	<ul style="list-style-type: none"> • Dismantle the iwis CLA lubrication pump and send it together with the lubricant cartridge and an error description to the manufacturer. • i A serious fault is most commonly in the electronic system of the iwis CLA lubrication pump and cannot be repaired on site. Please contact iwis antriebssysteme for in this case.

Operating Instructions: CLA Lubrication System

8.5. Input and output signals

The iwis CLA lubrication pump operates in Hour-Mode -h- as a time-based and cycle-controlled lubrication system according to the values set in the PRO menu.

8.5.1. Pin assignment – Time control

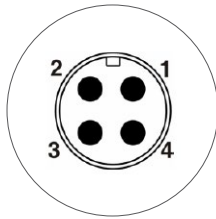

PIN	Assignment	Colour
1	+24 V DC	brown
2	unallocated	white
3	Ground	blue
4	output signal	black

Type: M12x1 female connector; 4-pin, A-coded

The iwis CLA lubrication pump can be switched off completely by switching off the supply voltage. The settings will not be lost. The elapsed time until the next scheduled lubrication cycle is automatically stored by the iwis CLA lubrication pump in the integrated microelectronics. After reapplying the supply voltage, the iwis CLA lubrication pump automatically checks itself and continues to operate according to the set values.

- i** After a longer standstill of the iwis CLA lubrication pump the manual execution of the „Quick-Check“ is recommended (chap. 7.4.1.).
- i** The output signal at PIN 4 can be tapped for further processing (e.g. indicator light or external control). The maximum permissible output current must not exceed $I_{\max} < 20\text{mA}$. No inductive load (e.g. relay) may be connected!

Operating Instructions: CLA Lubrication System

8.5.2. Output signals and LCD messages – time-controlled version

LCD	Description	Output Signal (Pin 4)	Detail
OFF	switched off	low, permanent	
On	Ready for operation	high, permanent	
E1	Cartridge empty	0,5Hz-square wave signal, permanent	Chap. 8.3.1.
E2	Overload	low, permanent	
E3	Undervoltage	low, permanent	
E4	Critical error	low, permanent	

8.5.3. Output signals at PIN 4 – time-controlled version

This iwis CLA lubrication pump provides two output signals in hour mode -h (factory setting) via the electrical interface. If required, the operating states of the iwis CLA lubrication pump can be processed externally. Basically, the output signals can only be sampled and must not be subjected to inductive loads or low ohmic loads. In addition to the optical display via LCD and LED on the iwis CLA lubrication pump, this also allows status control from a distance.

Output signal high level (+24 V) at PIN 4:

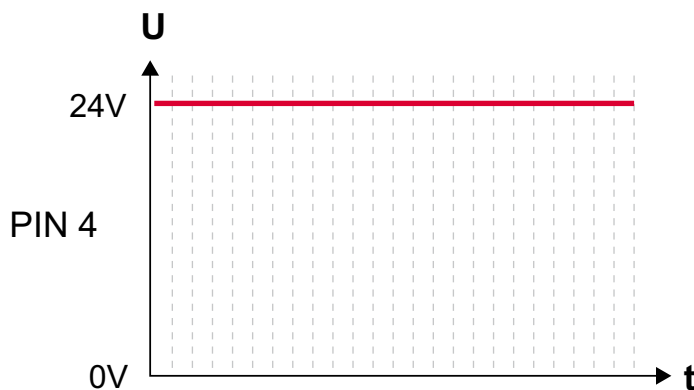

Description:

A permanently and continuously present high level (+24 V) at PIN 4 means that the iwis CLA lubrication pump is ready for operation and there is no error. The iwis CLA lubrication pump will operate according to the settings made and will accordingly convey lubricant from the cartridge to the outlet.

Operating Instructions: CLA Lubrication System

Output signal low level (0 V) at PIN 4:

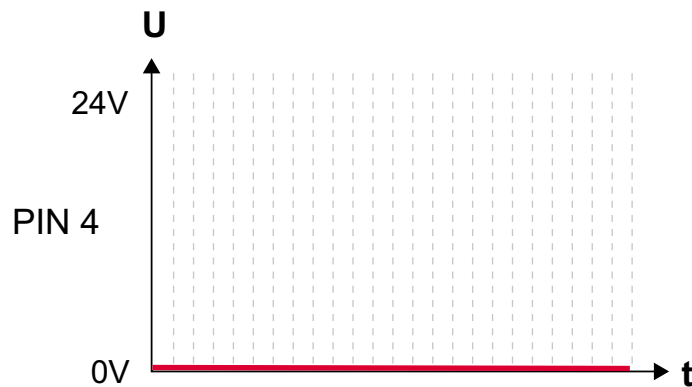

Description:

EA permanent low level (0V) at PIN 4 means that the iwis CLA lubrication pump is either switched off or – if it is switched on – there is an error. The error must be read on the LCD of the iwis CLA lubrication pump (chapter 8.4.). The iwis CLA lubrication pump does not pump lubricant!

Output signal 0,5Hz-square wave signal at PIN 4:

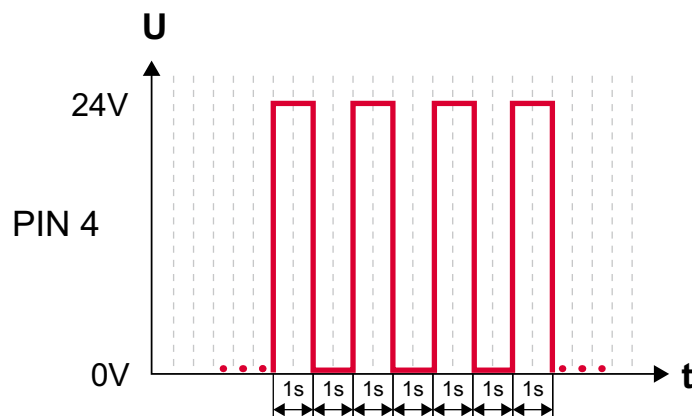

Description:

The integrated microelectronics of the iwis CLA lubrication pump is equipped with an automatic counter which counts the number of dispensing operations after a new and full cartridge has been fitted. For a cartridge with 400ml lubricant there are 2700 strokes. The small mathematical difference is considered as protection against the entering of air into the hydraulic system. The iwis CLA lubrication pump does not pump lubricant!

Operating Instructions: CLA Lubrication System

9. Maintenance and disposal

- Before starting any maintenance work, inform yourself about the general safety instructions (see Chapter 2) and observe the relevant local and operational safety regulations.
- Do not deactivate any protective device without authorization!

9.1. Maintenance schedule

The following maintenance schedule must be observed for the iwis CLA lubrication pump:

Maintenance	Commissioning	After 500 hours or after 3 months	Every year	If required
Cleaning	x	x	x	x*
Visual Check	x	x	x	x*
Lubrication Refill			x**	x*

* Depending on operating conditions and lubricant consumption, ** Recommendation after 2 years at the latest

9.1.1. Visual check

- Check the entire lubrication system (iwis CLA lubrication pump and any connected accessories including tubes and distributors) for external damage (e.g. loose or loose-ned tubes) by a thorough and conscientious visual inspection.
- Check the condition of the lubrication point for correct supply of lubricant.
- Replace damaged or defective parts immediately to ensure permanent lubrication.
- Check the filling level of the cartridge on the iwis CLA lubrication pump.
- Check possible error messages on the iwis CLA lubrication pump and remedy the causes accordingly.

9.1.2. Cleaning

Clean the iwis CLA lubrication pump from dirt using suitable cleaning agents (e.g. absorbent towels, cloths).

	NOTICE
	<p>Compressed air can damage the seals of the iwis CLA lubrication pump as well as transport dirt and foreign bodies into the iwis CLA lubrication pump or the lubricant.</p> <ul style="list-style-type: none"> • Do not use compressed air to clean the iwis CLA lubrication pump.

9.1.3. Recommissioning after maintenance

- Reinstall all safety devices and make sure that no tools remain in the danger area.
- Check that the iwis CLA lubrication pump is turned on.
- Carry out a „Quick Check“ (test run) using the control signal 2 seconds (chapter 7.4.1.).

Operating Instructions: CLA Lubrication System

9.2. Oil Refill

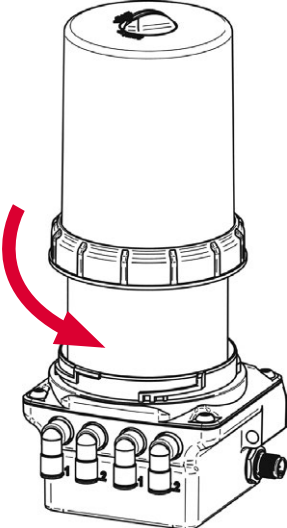
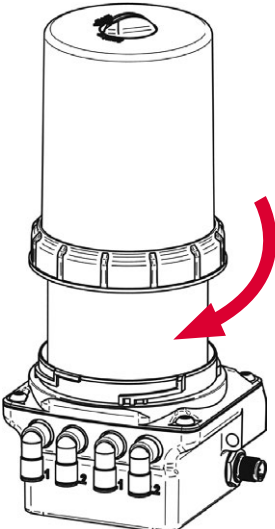
	<p>1. Remove the housing from the power unit of the iwis CLA lubrication pump.</p> <ul style="list-style-type: none"> Remove the housing from the power unit by turning the retaining ring counterclockwise. <p>i Make sure that no dirt, water or foreign bodies enters the lubricant inlet</p> <p>i As Alternative you can remove the lid on top of the housing, drehe to lay open the oil reservoir. Turn the lid to OPEN and pull it off.</p>
	<p>2. Filling of the cartridge with oil</p> <ul style="list-style-type: none"> Fill the cartridge with oil until the mark “max. Füllstand” is reached. <p>i Make sure you fill the cartridge neat, that no dirt, water or foreign bodies enters the lubricant inlet.</p>
	<p>3. Assembling the housing on the power unit of the iwis CLA lubrication pump.</p> <ul style="list-style-type: none"> Place the dismantled housing on the iwis CLA lubrication pump and press it onto the power unit. Fasten the housing to the power unit by turning the retaining ring clockwise. <p>i The retaining ring must snap into place when turning and be completely tightened.</p> <p>i Mount the lid back onto the housing, if you removed it for filling the oil cartridge. The lid has to be in the position CLOSE.</p>

Operating Instructions: CLA Lubrication System

9.3. Disposal

- When disposing the iwis CLA lubrication pump, empty or opened cartridges, observe the relevant national regulations in force.
- When disposing the iwis CLA lubrication pump, observe the relevant safety data sheets and disposal instructions for the individual components.

10. Released accessories

The present iwis CLA lubrication pump can be considerably extended by the extensive system and accessory program. This may necessitate changes to the PLC program, which controls the iwis CLA lubrication pump to ensure reliable and proper operation of the iwis CLA lubrication pump together with the hydraulically connected accessories.

10.1. Lubricants

Only use lubricants approved by iwis antriebssysteme GmbH & Co. KG in the original cartridges developed and manufactured exclusively for the iwis CLA lubrication pump.

	NOTICE
	<p>The lubricant used in each case differs according to the application. The respective designation can be found on the label of the canister label.</p>

Further information on lubricants, documentation and safety data sheets can be obtained directly from iwis antriebssysteme GmbH & Co. KG.

10.2. Tube length

In principle, the recommendation is to install the iwis CLA lubrication pump as close as possible to the consumer (lubrication point). Ideally, this should be done directly at or on the lubrication point. In cases where this is not possible due to the installation space or for reasons of reachability or accessibility, tubes can also be used between the iwis CLA lubrication pump and the lubrication point (or distributor).

If the case arises that you cannot mount the iwis CLA lubrication pump directly at the lubrication point, contact the manufacturer to verify your application.

The influence of temperature, the lubricant used, the hoses and accessories used does not allow a general statement to be made about the possible hose length on the iwis CLA lubrication pump.

Operating Instructions: CLA Lubrication System

11. Appendix

11.1. Dimension sheet and installation dimensions

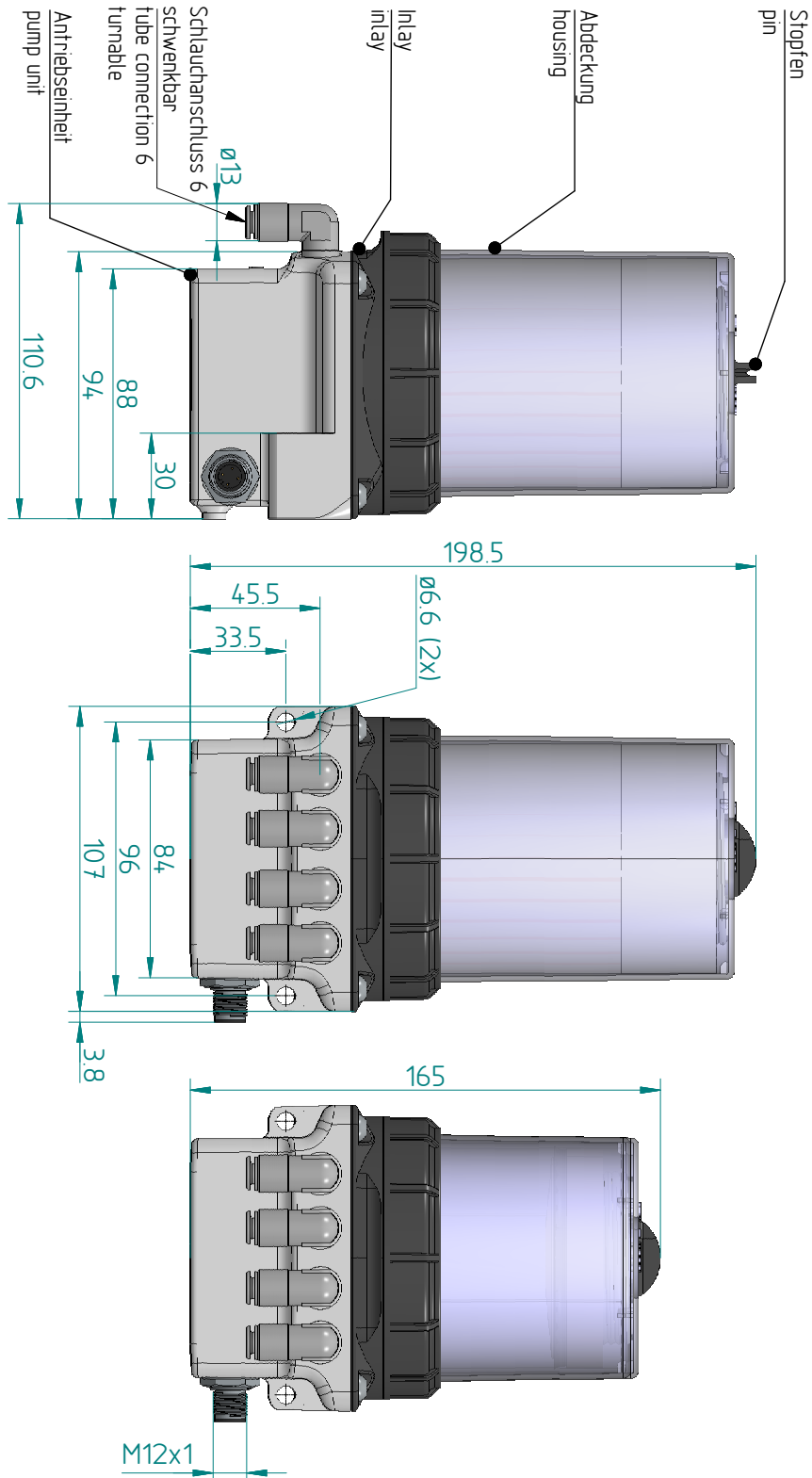

Operating Instructions: CLA Lubrication System

11.2. Flowchart Control signal 2 seconds (for PLC)

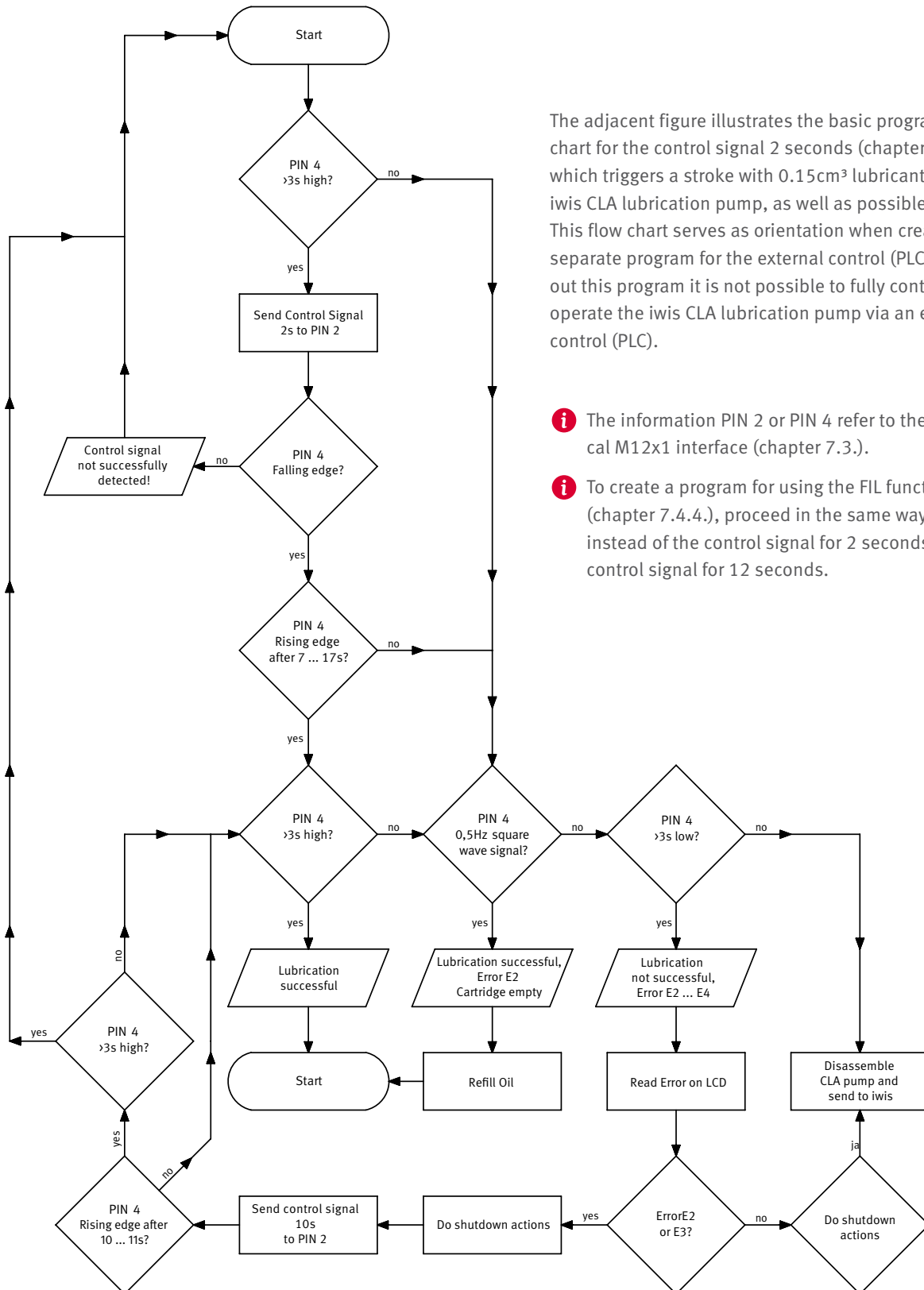

The adjacent figure illustrates the basic program flow chart for the control signal 2 seconds (chapter 8.2.1), which triggers a stroke with 0.15cm³ lubricant on the iwis CLA lubrication pump, as well as possible errors. This flow chart serves as orientation when creating a separate program for the external control (PLC). Without this program it is not possible to fully control and operate the iwis CLA lubrication pump via an external control (PLC).

- i** The information PIN 2 or PIN 4 refer to the electrical M12x1 interface (chapter 7.3.).
- i** To create a program for using the FIL function (chapter 7.4.4.), proceed in the same way, but instead of the control signal for 2 seconds, use the control signal for 12 seconds.

Operating Instructions: CLA Lubrication System

11.3. Commissioning the PU applicators

i The lubricating rollers are not intended to be manually supplied with lubricant!

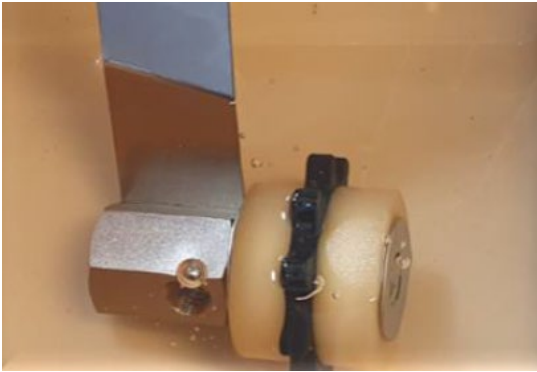
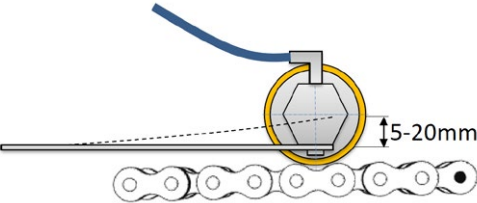
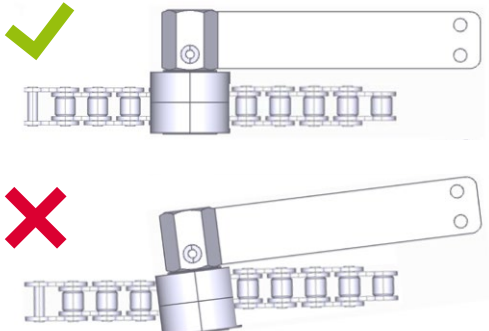
	<p>Prior to installation</p> <ul style="list-style-type: none"> • Under no circumstances may the lubricating rollers be operated dry! • The lubricating rollers must be soaked in oil before commissioning. • To do this, place the entire roller in an oil bath for a few minutes.
	<p>UNDER NO CIRCUMSTANCES MAY ANY PERMANENT IMPRESSIONS REMAIN ON THE SURFACE OF THE ROLLER!</p> <p>The lubricating rollers should only gently contact the chain.</p> <p>Ideally, the contact between the chain and the lubricating roller will be only strong enough to ensure that the roller turns together with the chain.</p> <p>Pre-tensioning of the sprung metal sheet: The pre-tensioning depends on the lubricant and on the speed of the chain. The roller must not slide.</p>
	<p>The lubricating rollers must make uniform contact across the entire width and must roll precisely in the direction of the drive.</p> <p>IF THEY ARE OUT-OF-TRUE, THEN THIS WILL CAUSE WEAR!</p>

Our subsidiaries

Germany

iwis antriebssysteme GmbH & Co. KG
Albert-Roßhaupter-Straße 53
81369 München
Tel. +49 89 76909-1600
Fax +49 89 76909-1198
sales-muenchen@iwis.com

Germany

iwis antriebssysteme GmbH
Essener Straße 23
57234 Wilnsdorf
Tel. +49 2739 86-0
Fax +49 2739 86-22
sales-wilnsdorf@iwis.com

Germany

iwis agrisystems
Schützenweg 5
36205 Sontra
Tel. +49 5653 9778-0
Fax +49 5653 9778-26
agrisystems@iwis.com

Brazil

iwis Sistemas de Transmissão
de Energia Mecânica Ltda.
Rua Bento Rosa, nº 1816
Bairro Hidráulica
95.900-000 Lajeado, RS
Tel. +55 51 3748-7402
salesbrazil@iwis.com

China

iwis drive systems (Suzhou) Co., Ltd.
No. 266 LvliangShan Road
215153 Suzhou SND
Tel. +86 512 8566-3010
Fax +86 512 8566-3009
salescn@iwis.com

France

iwis systèmes de transmission
10, rue du Luxembourg
69330 Meyzieu
Tel. +33 4374515-70
Fax +33 4374515-71
salesfr@iwis.com

Great Britain

iwis drive systems Ltd.
Unit 8c Bloomfield Park
Bloomfield Road, Tipton
West Midlands, DY4 9AP
Tel. +44 12 15213600
Fax +44 12 15200822
salesuk@iwis.com

India

iwis drive systems India Pvt. Ltd.
„Anisha“, Unit No3, SR. No. 84/1
Regency Cosmos, Baner Mahalunge Road,
Opposite to Amruta Hotel
Baner, Pune, Maharashtra-411045
Tel. +91 20 67110305
salesin@iwis.com

Italy

iwis drive systems Srl
Via Carlo Rota, 10
20090 Monza (MB)
Tel. +39 340 9296142
Fax +49 89 7690949-1726
italia@iwis.com

Canada

iwis drive systems, Inc.
101-19097, 26th Avenue,
Surrey BC V3Z 3V7
Tel. +1 604 560-6395
Fax +1 604 560-6397
salesca@iwisusa.com

South Korea

iwis engine systems Korea Co., Ltd.
Office No. 403-2, 322 Yanghyeon-ro
(Yatap-dong, Korea Design Center)
Bundang-Gu, Seongnam Si,
Gyeonggi-Do, Korea (ZIP) 13496
Tel. +82 31 788-7545
saleskor@iwis.com

Switzerland

iwis AG Kettentechnik
Bahnweg 4 (Postfach)
5504 Othmarsingen
Tel. +41 62 8898999
Fax +41 62 8898990
info@iwis-ketten.ch

South Africa

iwis drive systems, (Pty) Ltd.
Unit 3, 127 Koornhof Road
Meadowdale, 1613
Tel. +27 11 392-2306
Fax +27 11 392-3295
salessa@iwis.com

Czechia

iwis antriebssysteme spol. s r.o.
Písecká 893
38601 Strakonice
Tel. +420 383 411811
Fax +420 383 321695
salescz@iwis.com

Turkey

iwis tahrik sistemleri ltd. şti.
Kağıthane Ofis Park 4C-Blok
Bağlar Cad. No: 14
34406 Kağıthane-Istanbul
Tel. +90 212 939-3843
Fax +90 212 939-3701
salestr@iwis.com

USA

iwis drive systems, LLC
Building 100, 8266 Zionsville Road
Indianapolis, IN 46268
Tel. +1 317 821-3539
Fax +1 317 821-3569
sales-us@iwis.com

www.iwis.com

Your sales representative

